



Kent County Planning Commission
Department of Planning, Housing, and Zoning
400 High Street, Suite 130
Chestertown, MD 21620
410-778-7423 (voice/relay)

**County Commissioners Hearing Room
400 High Street
Chestertown, Maryland**

**AGENDA
June 3, 2021
1:30 p.m.**

Members of the public are now welcome to attend meetings in person, virtually, or via conference call. You may also listen to the meeting either online at <https://www.kentcounty.com/commissioners/meeting-live-video> OR via the audio-only phone number and conference identification number listed below. If listening to the meeting online, the way for members of the public to provide verbal comments during the meeting is via the audio-only phone number.

Public participation and audio-only call-in number:

1. Dial **1-872-239-8359**
2. Enter Conference ID: **459 507 60#**

Members of the public are asked to mute their phones/devices, until the Commission Chair opens the floor for comment. Please note that if you are listening to the online livestream while waiting to call in to participate, there is an approximately 45-second delay. In order to avoid audio feedback issues, please mute the livestream before calling in.

MINUTES

May 6, 2021

APPLICATIONS FOR REVIEW

#21-22 David A. Bramble, Inc. – (BOA) Special Exception – Renewal of Existing Sand & Gravel Pit
8415 Rock Hall Road – Sixth Election District – Zoned Agriculture Zoning District (AZD)
.....PC Recommendation to BOA

GENERAL DISCUSSION

2020 Annual Report – Letter to MDP

STAFF REPORTS

ADJOURN

Meetings are conducted in Open Session unless otherwise indicated. All or part of the Planning Commission meetings can be held in closed session under the authority of the MD Open Meetings Law by vote of the members. Breaks are at the call of the Chairman. Meetings are subject to audio and video recordings.

Projects will not be reviewed prior to their scheduled time. All applications will be given the time necessary to assure full public participation and a fair and complete review of all projects. Agenda items are subject to change due to cancellations.

Other business without assigned times may be discussed during the meeting.

MINUTES

The Kent County Planning Commission met in regular session on Thursday, May 6, 2021, virtually in the County Commissioners' Hearing Room at 400 High Street, Chestertown, Maryland, with the following members attending via audio/video conference: F. Joseph Hickman, Vice Chairman; County Commissioner P. Thomas Mason; Tyler Brown, Paul J. Ruge, Jr.; James Saunders; William Sutton (attending in-person); and Cynthia L. McCann, Esq., Planning Commission Attorney; Staff in attendance were William Mackey, Director; Carla Gerber, Deputy Director; and Sandy Adams, Clerk.

Mr. Hickman called the meeting to order at 1:30 p.m.

MINUTES

Mr. Saunders made a motion to accept the minutes of the April 1, 2021 meeting as distributed.

Mr. Ruge seconded the motion; the motion passed with all in favor.

APPLICATIONS FOR REVIEW:

21-11 Strong Associates, II LP – Buffer Variance

Ms. Gerber gave a description of the proposal, cited the applicable laws, staff and TAC's comments, and staff's recommendation.

Mr. Robert Strong, representative and co-owner of Strong Associates, II L.P., is requesting a variance to the Critical Area buffer standards in order to replace and slightly expand an existing cottage. The cottage is entirely within the Critical Area buffer and sits 40.4 feet from the mean high-water line. The proposed expansion is a widening of the foundation to align the exterior walls of the northern most section with the middle section of the cottage. The cottage was placed on the property in 1967 and consists of three smaller structures that were joined together when they were relocated from Eastern Neck Island by the applicant's father.

The 107-acre property is located on Eastern Neck Road, adjacent to Church Creek in the Fifth Election District and is zoned Resource Conservation District (RCD). The parcel is predominantly devoted to agriculture but consists of a primary dwelling and accessory storage structures outside of the buffer with a driveway leading to two cottages within the 100-foot buffer. Both cottages are also in the 1-percent annual chance (100-year) floodplain. The replacement and expansion are proposed for the cottage to the north. The surrounding area is zoned Resource Conservation District and Agricultural Zoning District.

Ms. Gerber said the existing cottage is a nonconforming use and structure that the applicant is voluntarily removing. Past interpretation of Article VIII, Nonconformities, has not allowed for the in-kind replacement of nonconforming structures unless a variance is granted. However, the Critical Area Law does not require a buffer variance for in-kind replacement, which is defined as "the removal of a structure and the construction of another structure that is smaller than or identical to the original in use, footprint area, width, and length." The Critical Area Law does require a variance for the expansion of the foundation to align the exterior walls. In its letter, the Critical Area Commission staff note that in order to grant the variance, the Board of Appeals will need to make findings that the variance meets every variance standard.

Ms. Gerber read into the record the response from the Critical Area Commission.

Mr. Robert H. Strong, 105 Court Street, Chestertown, Maryland, was present (in-person) at the meeting and presented his case. Mr. Strong was sworn in.

Mr. Strong informed the Commission that he and his sister are the applicants, and they were raised on the property which was known as Overton Farm. He said they are requesting to replace a dilapidated and mold filled structure with a short extension on the northern part of the foundation so that the last two sections are in alignment.

Mr. Hickman made a motion to send a favorable recommendation to the Board of Appeals to replace the cottage in the critical area buffer. The Commission's decision was based on the following findings:

- The structure currently exists in the critical area buffer and was built prior to the current critical area law and zoning regulations.
- The Comprehensive Plan and Critical Area law restricts development activities in the buffer, but in-kind replacement is allowed by the Critical Area law.

Mr. Ruge seconded the motion; the motion passed with all in favor.

Mr. Hickman made a second motion to send a favorable recommendation to the Board of Appeals for a buffer variance to expand the footprint to allow alignment of the exterior walls. The decision was based on the following findings:

- The variance will not cause a substantial detriment to adjacent or neighboring property.
- The variance will not change the character of the neighborhood or district.
- The variance is consistent with the Comprehensive Plan and the general intent of the Ordinance.
- The practical difficulty was not caused by the applicant's own actions. The structure existed in the Critical Area buffer prior to Critical Area law and current zoning regulations; and the structure is unsafe due to flood damage from Tropical Storm Isabel in 2003.
- The granting of the variance will be in harmony with the general spirit and intent of the Critical Area law and the regulations adopted by Kent County.
- The granting of the variance will not adversely affect water quality or adversely impact fish, wildlife, or plant habitat.
- The application for the variance was made in writing with a copy provided to the Critical Area Commission.
- The strict application of Critical Area Law and the Ordinance produces an unwarranted hardship.
- The hardship is not shared generally by other properties in the same zoning district and the same vicinity.
- The authorization of the variance will not be a substantial detriment to adjacent property and the character of the district will not be changed by the granting of the variance.
- The literal interpretation of the Ordinance deprives the applicant of rights commonly enjoyed by other properties in similar areas within the Critical Area of Kent County.
- The granting of the variance will not confer upon the applicant any special privilege that would be denied by this Ordinance to other lands or structures.
- Due to the special features of the site, or special conditions or circumstances peculiar to the applicant's land or structure, the literal enforcement of this Ordinance would result in unwarranted hardship to the applicant.
- The Commission finds that the applicant has satisfied each one of the variance provisions.
- The Commission finds that without the variance, the applicant would be deprived of a use of land or a structure permitted to others in accordance with the provisions of the critical area program.

Mr. Ruge seconded the motion; the motion passed with all in favor.

21-12 James Peary – Setback Variances (Front & Rear Yards) and Critical Area Clearing

Ms. Gerber gave a description of the proposal, cited the relevant issues, staff and TAC's comments, and staff's recommendation.

James Peary is requesting a 2-foot variance from the 50-foot front setback requirement and 2.5-foot variance from the 30-foot rear setback requirement in order to construct a new single-family dwelling. Mr. Peary also needs a variance to clear more than 30% of the woody vegetation on the entirely wooded 12,000 square foot lot.

The parcel is located at the corner of North Bayview Drive and Vermont Avenue in Tolchester Estates in the 6th Election District and is zoned Critical Area Residential (CAR). The surrounding area is characterized by residential development.

Ms. Gerber said staff recommends approval of the setback variances and the forest clearing variance.

Mr. James Peary, 9262 N. Bayview Avenue, Chestertown, Maryland, presented his case. Mr. Peary was sworn in.

Mr. Peary informed the Commission that the parcel he is proposing to develop is across the street from the property that he owns and has lived in for the past 22 years. He said he would like to construct a small guest house on the property for family. He said the property is currently completely wooded and some areas are overgrown.

Mr. Hickman made a motion to send a favorable recommendation to the Board of Appeals for a setback variance based on the following findings:

- The variance will not cause a substantial detriment to adjacent or neighboring property.
- The variance will not change the character of the neighborhood or district.
- The variance is consistent with the Comprehensive Plan and the general intent of the Ordinance to develop areas with public water and sewer.
- The practical difficulty is caused by the small size of the property and not by the applicant's own actions.
- The Commission believes that by granting the variance, it allows Mr. Peary reasonable use of the property.
- The granting of the variance will be in harmony with the general spirit and intent of the Critical Area Law and the regulations adopted by Kent County.
- The applicant has not commenced any development activity prior to seeking variance approvals; and the applicant's proposed plans have been designed thoughtfully for the Tolchester Estates community.

Mr. Ruge seconded the motion; the motion passed with all in favor.

Mr. Hickman made a motion to send a favorable recommendation to the Board of Appeals for a forest clearing variance based on the following findings:

- The property is entirely wooded. In order to construct a reasonable dwelling, the applicant must clear 39% of the property.
- The variance will not cause a substantial detriment to adjacent or neighboring property.
- The variance will not change the character of the neighborhood or district.
- The variance is consistent with the Comprehensive Plan and the general intent of the Ordinance to develop areas with public water and sewer.
- The practical difficulty is caused by the small size of the property and not by the applicant's own

actions.

- The Commission believes that by granting the variance, it allows Mr. Peary reasonable use of the property.
- The granting of the variance will be in harmony with the general spirit and intent of the Critical Area Law and the regulations adopted by Kent County.
- The applicant has not commenced any development activity prior to seeking variance approvals.
- The applicant will mitigate and/or provide a fee in-lieu to the forest conservation fund where mitigation is not possible.

Mr. Sutton seconded the motion; the motion passed with all in favor.

STAFF REPORTS

Mr. Mackey:

- On Tuesday evening, the County Commissioners instructed staff to open the buildings to the public. Mr. Mackey informed the Commission that in person meetings are now an option.
- The Task Force will meet next Wednesday, May 12th, at 6:00 p.m.

Carla Gerber:

- The department has received approximately 23-24 applications from landowners who want to sell an easement to the Maryland Agricultural Land Preservation Foundation.
- We continue to review many building permits and assist many callers.

Ms. McCann:

- There are no legal issues to report.

Vice Chairman Hickman welcomed Tyler Brown, the newest member on the Commission; Mr. Brown gave a brief self-introduction to the Commission.

ADJOURN

There being no further business for the good of the organization, the meeting adjourned at 2:19 p.m.

Joe Hickman, Vice Chairman

Sandy Adams, Clerk

DRAFT

PRELIMINARY STAFF REPORT

TO: Kent County Board of Appeals
SUBJECT: David A. Bramble, Inc. (Margaret K. Bramble, LLC)
Sand & Gravel Pit Special Exception Renewal
DATE: May 27, 2021

DESCRIPTION OF PROPOSAL

David A. Bramble, Inc., requests renewal of the special exception to continue operation of an existing sand and gravel pit on a 164.675-acre property owned by Margaret K. Bramble, LLC, located 8415 Rock Hall Road (MD Route 20) near Fairlee. The excavation site comprises 19.66 acres located interior to the property, which is also otherwise farmed, and only 25 percent of the allowed area of the operation is used at one time. Access to the sand and gravel pit is by an unimproved lane from MD Route 20 that also serves a residential lot and agricultural structures on the farm. The applicant's narrative advised that there are no employees permanently located at this site. The materials excavated from this sand and gravel pit support the operation of David A. Bramble, Inc.

The parcel is zoned "AZD", Agricultural Zoning District, and is generally surrounded by farmland and woodland. In 2018, the Orem family completed two adjustments of lot lines for two residential lots located interior to the property (Parcel 8, Lot 2 and Parcel 157). In 2019, Margaret K. Bramble, LLC, purchased Parcel 8, Lot 2 on which is located the house closest to the gravel pit. Parcel 157 is owned by an unrelated party. One of the adjustments of lot lines inadvertently encroached on the gravel pit by 1.37 acres. As part of this renewal application, the applicant is seeking to shift that 1.37 acres to the west side of the pit limits.

HISTORY

The initial conditional use/special exception approval for the operation of this sand and gravel pit was granted 1984. Since that time, updated approvals have been regularly granted and the last renewal was approved in 2016. The conditions of approval were:

- The operation shall not be enlarged beyond 19.66 acres.
- The special exception shall be granted for a period of five (5) years.
- The operation must have an approved operating and restoration plan from the Surface Mining Division of the Maryland Department of the Environment's Water Resources Administration (the "SMD") in place at all times.
- The applicant's mining permit, sediment and erosion control plan, and operating and restoration plan must be strictly followed at all times.
- Final signature approval of the site plan.

RELEVANT ISSUES

I. SPECIAL EXCEPTION GENERAL REVIEW CRITERIA

- A. *Comprehensive Plan*: "Conserve the County's mineral resources for future use while safeguarding the environment and surrounding communities." page 83
- B. *Applicable Law*: Article VII, Section 2 of the *Kent County Land Use Ordinance* sets forth the standards applicable to all special exceptions as follows:

The Board, or where applicable the Planning Director, shall make findings on the following where appropriate:

1. The nature of the proposed site, including its size and shape and the proposed size, shape, and arrangement of structures;
2. Traffic Patterns;
3. Nature of surrounding area;
4. Proximity of dwellings, houses of worship, schools, public structures, and other places of public gathering;
5. The impact of the development or project on community facilities and services;
6. Preservation of cultural and historic landmarks, significant natural features and trees;
7. Probable effect of noise, vibration, smoke and particulate matter, toxic matter, odor, fire or explosion hazards, or glare upon surrounding properties;
8. The purpose and intent of this Ordinance as set forth in Article II;
9. Design, environmental, and other standards of this Ordinance as set forth in Article V;
10. The most appropriate use of land and structure;
11. Conservation of property values;
12. The proposed development's impact on water quality;
13. Impact on fish, wildlife and plant habitat,
14. Consistency with the Comprehensive Plan, Land Use Ordinance, and where applicable the Village Master Plan;
15. Consistency with the Critical Area Program; and
16. Compatibility with existing and planned land use as described in the Comprehensive Plan, Land Use Ordinance, and where applicable the Village Master Plan.

C. *Staff and TAC Comments:* A sand and gravel pit has been in operation at this site for more than 35 years without complaint from surrounding property owners or residents. Although the applicant is seeking to shift the pit boundaries, the applicant is not seeking to expand the area of operation. The remainder of the property is wooded or used for agricultural purposes. Relative to the applicable findings, staff offers the following:

- The size of the property is more than adequate for the existing use. Approximately 50-feet will be added to the western side of the pit to offset 1.37 acres of the pit that was inadvertently included in Parcel 157, which is now owned by an unrelated party. The pit will still be over 350 feet from the western property line.
- Trucks enter and depart the site by an existing unimproved stone lane from MD Route 20. Renewal of the special exception will not result in changes to traffic patterns as the number of trucks will not increase per the applicant's narrative. The State Highway Administration has no issues or concerns with County approval.
- The nature of the area is farmland and woodland.
- The closest places of public gathering are Potter's House Ministries, Inc., and Salem Methodist Church, both in the Village of Fairlee, less than one mile to the north. St. Paul's Church is located less than two miles to the south on Sandy Bottom Road.
- During the course of prior renewals, the record has been devoid of any evidence that the use would have a negative impact on community facilities and services.
- There are no cultural and historic landmarks or significant natural features in the vicinity that would be adversely impacted by the use. Forested areas or woodlands on the farm will not be disturbed by this operation.
- As stated in their narrative, the applicant has appropriate measures in place to control potential negative effects from noise, vibration, smoke and particulate matter, toxic matter, odor, fire or explosion hazards, or glare upon surrounding properties.

- There are no known threatened or endangered species, areas of specific value, or rare assemblages of species or other vital habitat are located within the limits of the pit. Environmentally sensitive areas on the farm, such as the West Fork of Langford Creek, will not be disturbed.
- The operation has been in existence since 1984 and renewed on five year cycles. There is no reason to believe that the surrounding properties will be negatively impacted by the continuation of the operation. Additionally, the 2011 renewal noted that in light of the site's topography and existing forested areas, additional screening was not required.
- With the prior renewals the record has been devoid of any evidence that the use would impact property values, water quality, fish, wildlife, or plant habitat.
- The proposal is consistent with the Comprehensive Plan, the general intent and the use, design, and environmental standards found in the *Land Use Ordinance*.

II. SAND AND GRAVEL PIT SPECIAL EXCEPTION REVIEW CRITERIA

- A. *Comprehensive Plan*: "Sand and Gravel are the predominant minerals found in Kent County. An unusual seam of high-quality spec and concrete sand and gravel runs southeasterly from Baltimore County to Lewes Delaware. These aggregates are vital to a healthy economy and Kent County recognizes that sand and gravel are resources of increasing commercial value." Page 83
- B. *Applicable Law*: Article VII Section 7.52 of the *Ordinance* grants the Board of Appeals the authority to grant a special exception for gravel pits, excavation or extraction (not including the removal of sod, and excavation for foundations, swimming pools, soil and water conservation practices, and those removals approved in connection with farm use, street construction, subdivision or planned residential development) in AZD, RCD, RC, RR and CAR provided:
- a. The special exception shall be for a period not to exceed five years
 - b. Material is not brought from off-site for processing, mixing, or similar uses
 - c. The excavation or extraction operation shall be controlled to offer reasonable protection to surrounding properties and the neighborhood, particularly as regards to use of residential streets for access to the site
 - d. There are no known threatened or endangered species, areas of specific value, or rare assemblages of species or other vital habitat at the site
 - e. In RCD and CAR, highly erodible soils are not disturbed at the site
 - f. The operation will not disturb for future use prime agricultural lands or forest and developed woodlands of more than one acre
 - g. The operation will not degrade water quality
 - h. The operation does not disturb the minimum 100-foot buffer or stream protection corridor
 - i. The operation is under an approved operating and restoration plan from the State of Maryland
 - j. The operation does not adversely affect a non-tidal wetland directly or hydrologically
 - k. The location of the excavation or extraction with respect to property lines, the depth of excavation, and relation to the water table or flood criteria and the slope of the sides of the excavation shall be controlled to prevent a continuing, unsightly, hazardous, or wasteful condition of the land.
- C. *Staff Comments*: The proposal is consistent with the Mineral Resources element of the Comprehensive Plan. Additionally, the reclamation plan as approved by the Maryland Department of the Environment permits the on-site use of dredged material from maintenance dredging of the Rock Hall Harbor Channel. Further;
- The operation has been in existence since 1984 and the special exception consistently renewed.
 - The applicant's narrative asserts that materials will not be brought from off site for mixing or processing.

- As stated in their narrative, the applicant has appropriate measures in place to control deleterious effects from noise, vibration, smoke and particulate matter, toxic matter, odor, fire or explosion hazards, or glare upon surrounding properties. Trucks enter and depart the site by an existing unimproved stone lane from MD Route 20. Renewal of the special exception will not result in increased traffic as the number of trucks will not increase since the area of the pit is not expanding. The State Highway Administration has advised that the entrance is currently suitable for continued access.
- There are no known threatened or endangered species, areas of specific value, or rare assemblages of species or other vital habitat located within the limits of the pit. Environmentally sensitive areas on the farm, such as the West Fork of Langford Creek, will not be disturbed.
- The property is zoned AZD.
- The project may disturb more than 5 acres of prime soil, but the site will be reclaimed for future use. Forested areas or woodlands on the farm will not be disturbed by this operation.
- With the prior renewals, the record has been devoid of any evidence that the use would impact property values, water quality, fish, wildlife, or plant habitat.
- The upper reaches of the West Fork of Langford Creek and affiliated non-tidal wetlands are located along the southeast edge of the farm but will not be disturbed by the pit. The creek is sufficiently to the rear of the farm property such that this operation does not impact the 100-foot stream protection corridor or affiliated non -tidal wetlands.
- The operation has an approved operating and restoration plan from the State of Maryland.
- The sediment control plan will expire in September. The applicant will have the plans renewed before they expire.

STAFF RECOMMENDATION:

Staff recommends forwarding a favorable recommendation with the same conditions of approval from 2016:

- The operation shall not be enlarged beyond 19.66 acres.
- The special exception shall be granted for a period of five (5) years.
- The operation must have an approved operating and restoration plan from the Surface Mining Division of the Maryland Department of the Environment's Water Resources Administration (the "SMD") in place at all times.
- The applicant's mining permit, sediment and erosion control plan, and operating and restoration plan must be strictly followed at all times.



Davis, Moore, Shearon & Associates, LLC

May 10, 2021

Mr. William Mackey, Planning Director
Kent County Department of Planning & Zoning
400 High Street
Chestertown, Maryland 21620

**RE: BOARD OF APPEALS SPECIAL EXCEPTION APPLICATION FOR THE
CONTINUATION OF AN EXISTING SAND AND GRAVEL PIT, LANDS OF
MARGARET K. BRAMBLE, LLC
KENT COUNTY TAX MAP 42 PARCEL 8, LOT 1
DMS & ASSOCIATES JOB #2021078**

Dear Mr. Mackey,

Attached please find a Board of Appeals Special Exception application for the continued operation of an existing sand and gravel pit. The pit is commonly referred to as the Orem Pit, and is operated by David A. Bramble, Inc. The property is currently owned by Margaret K. Bramble, LLC. Please find the following information in support of this application:

- One copy of the Board of Appeals Application
- Three copies of the Site Plans
- \$350 application fee check

The request is based on Article V, Section 1.3.24 which states that a sand and gravel pit requires a Special Exception in the Agricultural Zoning District.

The total area of the approved pit to date is 18.46 acres. A lot line adjustment that occurred in 2018 between Lisa M. Orem and Marie L. Orem (Tax Map 42, Parcel 8, Lot 1) inadvertently placed part of the pit's footprint on the Lisa M. Orem parcel (Tax Map 42, Parcel 157). Attached is a copy of the recorded lot line adjustment (MLM 5/197) for reference. As part of this updated Special Exception we are proposing to shift the 1.37 acres of the approved pit's footprint from Parcel 157 (currently owned by Brian A. and Elizabeth C. Councell) solely onto Parcel 8, Lot 1 (currently owned by Margaret K. Bramble, LLC). Approximately 50-ft will be added to the western pit boundary as shown on the attached aerial image exhibit to offset the 1.37 acres.

We ask that you please review this information and place the request on the next T.A.C. agenda.
If you have questions please call me at 443-262-9130.

Sincerely,

DMS & Associates, LLC



Kevin J. Shearon, P.E., LEED AP

Enclosures

pc: Ms. Megan Owings, David A. Bramble, Inc.

BOARD OF APPEALS APPLICATION

Kent County Department of Planning, Housing and Zoning

Kent County Government Center
400 High Street • Chestertown, MD 21620
410-778-7475 (phone) • 410-810-2932 (fax)

**IN THE MATTER OF THE APPLICATION OF:
(Name, Address and Telephone Number of Applicant)**

David A. Bramble, Inc.

PO Box 419 705 Morgnec Road

Chestertown, Maryland 21620

Email: megan@davidabrambleinc.com

TO THE KENT COUNTY BOARD OF APPEALS: In accordance with Article 10 Section 2.2
of the Kent County Zoning Ordinance, as amended, request is hereby made for:

_____ Appealing Decision of Kent County Zoning Administrator _____ Variance
 Special Exception _____ Non-conforming Use

DESCRIPTION OF PROPERTY INVOLVED:

Located on: (Name of Road, etc.) 8415 Rock Hall Road, Chestertown, Maryland

In the 6th Election District of Kent County.

Size of lot or parcel of Land: 164.67

Map: 0042 Parcel: 0008 Lot #: 1 Deed Ref: MM 992/001

List buildings already on property: Residence; sheds

If subdivision, indicate lot and block number: N/A

If there is a homeowners association, give name and address of association: N/A

PRESENT ZONING OF PROPERTY: AZD

DESCRIPTION OF RELIEF REQUESTED: (List here in detail what you wish to do with property that requires the Appeal Hearing.) Continue operation of sand and gravel pit.

If appealing decision of Zoning Administrator, list date of their decision: _____

Present owner(s) of property: Margaret K. Bramble, LLC Telephone: 410-778-3023

If Applicant is not owner, please indicate your interest in this property: Operator of sand and gravel pit.

Has property involved ever been subject to a previous application? Yes

If so, please give Application Number and Date: Case #: 16-03, Special Exception (granted June 13, 2016)

For Office Use Only:
Case Number/Date Filed: _____
Filed by: _____
Applicant: _____
Planning Commission: _____
Date of Hearing: _____
Parties Notified: _____
Notice in Paper: _____
Property Posted: _____

PLEASE FILL IN BELOW, OR ATTACH HERETO, A SKETCH OF THIS PROPERTY.

List all property measurements and dimensions of any buildings already on the property.

Put distances between present buildings or proposed buildings and property lines.

NAMES OF ADJOINING PROPERTY OWNERS:

Owner(s) on the North: Joseph C. Gsell; Joyce Redman; Brian A. and Elizabeth C. Councill

AMERICAN TOWERS INC C/O AMERICAN TOWERS CORP

Owner(s) on the South: Merkle, Edgar Kent Trustee & Merkle, Carole N. Trustee; Bigelow, Nelda, Michael D. & Kathleen Hildenbrand; LANGFORD WEST LLC; REDMAN FAMILY FARMS LLC

Owner(s) to the East: _____

Owner(s) to the West: Tulip Forest Farming Corp.

Homeowners Association, name and address, if applicable: N/A

BY SIGNING THIS APPLICATION I GRANT MEMBERS AND ALTERNATE OF THE BOARD OF ZONING APPEALS THE RIGHT TO ENTER ONTO THE PROPERTY FOR THE PURPOSE OF VIEWING THE SITE OF THE APPLICATION OR APPEAL.



Signature of Owner/Applicant/Agent or Attorney

5/6/2021

Date

David C. Bramble, President
DAVID A. BRAMBLE, INC.

Please file this form at 400 High Street, Chestertown, MD 21620 accompanied by **\$350.00** filing fee made payable to the Board of Appeals. If you have any questions, contact Clerk at 410-778-7467.

NOTICE: Neither the Board of Appeals or the Planning Office is required to make out this Application. Application should be filled in by applicant or its agent. If the Planning Office assists you, they cannot be held responsible for its contents.

Applicants arriving more than 10 minutes after the scheduled hearing will not be heard and will be re-scheduled at the applicant's expense.

Margaret K. Bramble, LLC

(410)778-3023/(410)778-3427 (FAX) * 705 MORGNEC ROAD/P. O. BOX 419 * CHESTERTOWN, MD 21620

May 10, 2021

Re: Project: David A. Bramble, Inc.
Renewal of Sand & Gravel Pit
Application No.: # _____ and # _____
Special Exception & Site Plan

Two Whom It May Concern:

Margaret K. Bramble, LLC is the owner of the property on which David A. Bramble, Inc. operates a sand and gravel pit. The current special exception for the sand and gravel pit expires in June.

As the property owner, for purposes of the application file, please note our support and consent to renewal of the special exception for a sand and gravel pit on our property.

Sincerely,
Margaret K. Bramble, LLC



Megan B. Owings, Member

DAVID A. BRAMBLE, Inc. *General Contractors*

(410)778-3023/(410)778-3427 (FAX) * 705 MORGNEC ROAD/P. O. BOX 419 * CHESTERTOWN, MD 21620

BEFORE THE KENT COUNTY BOARD OF APPEALS

IN THE MATTER OF

KENT COUNTY, MARYLAND

Margaret K. Bramble, LLC

CASE NO. _____

SPECIAL EXCEPTION APPLICATION

May 10, 2021

NARRATIVE

In Kent County, Maryland, sand and gravel pits are permitted as a special exception in the Agricultural Zoning District (AZD). See the Land Use Ordinance for Kent County, Maryland (the "Ordinance"), at Article V. §1.3, Special Exceptions in the AZD. David A. Bramble, Inc. ("Bramble" or "Applicant") has successfully operated a sand and gravel pit at this location for over 35 years. This application is for renewal of the current approval, with a proposed relocation of the pit limits without an increase in the pit size.

Pursuant to the Ordinance, Article VII §6 Procedures for Special Exceptions:

The application for a special exception shall include a site plan together with such data and information as may be required for a determination of the nature of the proposed use and its effect on the Comprehensive Plan, the neighborhood, and surrounding properties.

In the case of a sand and gravel pit, the Planning Commission shall review the application and send a recommendation to the Board of Appeals.

What follows is Applicant's narrative of the Site Plan Review standards and Special Exception Review standards for consideration:

SITE PLAN REVIEW STANDARDS

The Ordinance at §VI.5, "Site Plan Review" requires the Applicant to provide a narrative addressing the elements below. The elements and the Applicant's responses are as follows:

1. *Name and address of the landowner, the developer and/or representative, if different from the owner.*

Owner: Margaret K. Bramble, LLC

Operator: David A. Bramble, Inc.

Address: P.O. Box 419, Chestertown, Maryland 21620

2. Street address, tax map, parcel number, and subdivision if any.

8415 Rock Hall Road
MAP 0042, Parcel 0008

Margaret K. Bramble, LLC (“MKB”) purchased the property from the Orem family in March of 2019. Bramble leases the sand and gravel pit from MKB, just as Bramble leased it from the Orem family previously. Prior to MKB purchasing the property, the Orem family recorded several lot line adjustments, which increased the sizes of two family lots located interior to the property, which are Parcel 8 (Lot 2) and Parcel 157. Lot 2, which is closest to the sand and gravel pit, was purchased by MKB in 2019. Parcel 157 is owned by an unrelated party that purchased the parcel in 2018. When the Orem family increased the size of Parcel 157, the new lot configuration of Parcel 157 encroached on the long-established pit limits of the pit operation by 1.37 acres. As a result, in this renewal application the Applicant seeks to shift that 1.37 acres from Parcel 157 to the property and add approximately 50-ft on the west side of the pit limits.

3. Zoning of site.

AZD

4. Current and proposed use of the property.

Farm, sand and gravel pit, one residence.

5. An explanation of the viewshed, open space, and conservation analysis undertaken during the design of the site plan

The Applicant first received special exception approval for the sand and gravel use in 1984 and received renewals of such approval through the latest approval dated June of 2016. The surrounding lands are used for agricultural purposes. The location of the existing use in the interior of the property greatly reduces the potential site and sound impacts of the use on adjoining property owners. The site plan presented is for the continued use of a sand and gravel pit. The site plan submitted reflects any necessary updates required by code, but otherwise is unchanged except as noted above in #2. The excavation site is 19.66 acres located interior of the 164.675 acre property. Only 25% of the allowed area of the operation is used at one time. There are no cultural and historic landmarks or significant natural features in the vicinity of the Property that will be adversely impacted by the Applicant’s operation of a sand and gravel pit. There are no forested areas or other woodlands on the Property that will be disturbed by such operation.

6. How the proposed development complies with the Comprehensive Plan and the design and environmental standards of this Ordinance.

The sand and gravel pit use continues to be consistent with the 2018 Kent County Comprehensive Plan (the “Comprehensive Plan”). At page 51, the Comprehensive Plan lists mineral resources, such as sand and gravel, as one of the County’s “important natural resources.” The Mineral Resource section (page 83) of the Comprehensive Plan, states that, “...aggregates are vital to a healthy economy, and Kent County recognizes that sand and gravel are resources of increasing commercial value.” The Comprehensive Plan sets a goal of conserving “...the County’s mineral resources for future use while safeguarding the environment and surrounding communities,” with strategies of monitoring infrastructure impacts from extraction operations and keeping current with mining regulations, especially with regard to reclamation and post-extraction plans. By virtue of the Special Exception process, the County has set a 5- year review of operations such as this. Additionally, the County recognizes in the Comprehensive Plan that retention and expansion of local businesses is key to the economic success of the County. (Comprehensive Plan page 8). The minerals from this pit support Bramble’s construction and asphalt operations. Bramble celebrated 60 years of incorporation in 2019, and is a third generation, family-owned business that is one of the larger employers in Kent County. The continuation of the sand and gravel use supports economic development in the County.

Additionally, surface mining sand and gravel has been declared by the Maryland General Assembly as “a basic and essential activity making an important contribution to the economic well-being of the State and the nation and that this activity must be balanced against potential health, safety, and environmental effects....” See Md. Code Ann., Environment §15-802.

The Application is also consistent with the design and environmental standards of the Ordinance as detailed in the Special Exception section below.

7. Number of employees.

There will be no employees permanently located at the site. The materials from the site support the operation of David A. Bramble, Inc., which has approximately 200 employees at this time.

8. The proposed development schedule and phases of development for all proposed construction.

The site will continue to be mined in 25% increments. Further expansions are anticipated on the western pit limits.

9. *Citizen Participation Plan*

The Applicant will work with the Planning Department in identifying property owners to be contacted by a mailing that will detail the application and that the request is for continuation of the sand and gravel use, which has been allowed on the property since 1984. At or before any hearing on the application we will report the results of the mailing.

SPECIAL EXCEPTION REVIEW STANDARDS

The Ordinance at §VII, "Special Exceptions" §2, "Standards" requires the Board of Appeals to make findings on the following where appropriate. The elements and the Applicant's responses are as follows:

1. *The nature of the proposed site, including its size and shape and the proposed size, shape, and arrangement of structures;*

The site is 164.675 acres, 19.66 of which the Applicant has operated the existing sand and gravel pit since 1984. The Applicant does not seek to expand the area for the sand and gravel operation, except as noted above regarding reconfiguration of the pit limits. The surrounding lands are used for agricultural purposes. The site is accessed via an unimproved lane off of Rock Hall Road, which also serves the agricultural structures and residence on the property. The size of the property is more than adequate for the existing sand and gravel use.

2. *Traffic Patterns;*

Renewal of the existing sand and gravel use will not result in increased traffic. The number of trucks utilizing the unimproved lane and Rock Hall Road will not increase. There is an average of 5 triaxle trucks per day.

3. *Nature of surrounding area;*
4. *Proximity of dwellings, houses of worship, schools, public structures, and other places of public gathering;*

The surrounding area is agricultural and wooded. The nearest places of public gathering are Potters House Ministries, Inc., and Salem Methodist Church, both in the Village of Fairlee, which is less than one mile to the north of the Property. St. Paul's Church is located less than two miles to the south of the Property on Sandy Bottom Road.

5. The impact of the development or project on community facilities and services;

There will be no impact on community facilities or services from the continuation of the use. There has never been any evidence presented in the course of prior renewals of the Applicant's special exception of negative impact on community facilities or services resulting from the Applicant's operation of a sand and gravel pit on the Property, and no such evidence has been presented with respect to the instant Application

6. Preservation of cultural and historic landmarks, significant natural features and trees;

There are no cultural, historic landmarks, or significant natural features and trees impacted by the use or present on the property.

7. Probable effect of noise, vibration, smoke and particulate matter, toxic matter, odor, fire or explosion hazards, or glare upon surrounding properties;

The Applicant has appropriate measures in place to control any such effects of noise, vibration, smoke and particulate matter, toxic matter, odor, fire or explosion hazards, or glare upon surrounding properties. The sand and gravel operation has been in existence since 1984 and the County has not received any complaints regarding any of these items, therefore there is no reason to believe that surrounding properties are negatively impacted by the operation or would be negatively impacted by the continuation of the operation.

8. The purpose and intent of this Ordinance as set forth in Article II;

The continuation of the existing use promotes the intent of the Ordinance by giving effect to the policies and proposal set forth in the Comprehensive Plan. The continuation of the use enhances the County's employment-base as noted previously herein. This is accomplished without impacting water quality or having a negative impact on the environment given the Applicant's mineral permit with the State, sediment and erosion control plan, and operating restoration plan.

9. Design, environmental, and other standards of this Ordinance as set forth in Article V;

The site plan is compliant with the Ordinance.

10. The most appropriate use of land and structure;

The sand and gravel use has previously been deemed an appropriate use on the property.

11. Conservation of property values;

There is no evidence that the Applicant's use of the Property will negatively impact any neighboring properties or property values. As noted in the Applicant's 2011 renewal, screening of the sand and gravel pit is not necessary due to the Property's topography and surrounding forested areas.

12. The proposed development's impact on water quality;

13. Impact on fish, wildlife and plant habitat;

There is no evidence that the proposed use will have any impact of water quality, fish, wildlife or plant habitat. There are no known threatened or endangered species, areas of specific value, or rare assemblages of species or other vital habitat at the site.

14. Consistency with the Comprehensive Plan, Land Use Ordinance, and where applicable the Village Master Plan;

15. Consistency with the Critical Area Program; and

The property is not in the Critical Area.

16. Compatibility with existing and planned land use as described in the Comprehensive Plan, Land Use Ordinance, and where applicable the Village Master Plan.

See discussion above at Site Plan Review Standards section, #6.

ARTICLE VII, Section 7, "Special Exceptions"

The particular use "sand and gravel pits, excavations or extractions" is permitted in the AZD if the use meets the criteria set forth at Article VII, §7.52. Accordingly, the Applicant hereby incorporates into the record the prior approvals for the use and asserts that the following criteria will continue to be satisfied:

SECTION 7. SPECIAL EXCEPTIONS

Buildings, structures, and uses for which special exceptions may be authorized and the additional standards relative thereto are as follows:

52. Sand and gravel pits, excavation or extraction (not including the removal of sod, and excavation for foundations, swimming pools, soil and water conservation practices, and those removals approved in connection with farm use, street construction, subdivision or planned residential development) in AZD, RCD, RC, RR and CAR provided:

- a. The special exception shall be for a period not to exceed five years
- b. Material is not brought from off-site for processing, mixing, or similar uses

- c. The excavation or extraction operation shall be controlled to offer reasonable protection to surrounding properties and the neighborhood, particularly as regards to use of residential streets for access to the site
- d. There are no known threatened or endangered species, areas of specific value, or rare assemblages of species or other vital habitat at the site
- e. In RCD and CAR, highly erodible soils are not disturbed at the site
- f. The operation will not disturb for future use prime agricultural lands or forest and developed woodlands of more than one acre
- g. The operation will not degrade water quality
- h. The operation does not disturb the minimum 100-foot buffer or stream protection corridor
- i. The operation is under an approved operating and restoration plan from the State of Maryland
- j. The operation does not adversely affect a non-tidal wetland directly or hydrologically
- k. The location of the excavation or extraction with respect to property lines, the depth of excavation, and relation to the water table or flood criteria and the slope of the sides of the excavation shall be controlled to prevent a continuing, unsightly, hazardous, or wasteful condition of the land.

COMMENT: In addition to previous findings for approval on this use at this location as well as the information provided in this narrative, please also note:

- The renewal of the Applicant's special exception will not exceed five years;
- Except as approved (i.e. dredge spoils), material shall not be brought from off-site for processing, mixing, or similar uses;
- The Applicant's operation is controlled to offer reasonable protection to surrounding properties and the neighborhood, particularly with respect to the use of residential streets for access thereto;
- There are no known threatened or endangered species, areas of specific value, or rare assemblages of species or other vital habitat on the Property;
- The Applicant's operation of a sand and gravel pit on the property does not disturb future use of prime agricultural lands or forest and developed woodlands of more than one acre, degrade water quality, or disturb the minimum 100-foot buffer or stream protection corridor;
- The operation is under an approved operating and restoration plan from the State of Maryland and does not adversely affect a non-tidal wetland directly or hydrologically; and
- The location of the Applicant's sand and gravel pit on the Property, with respect to property lines, the depth of excavation, and relation to the water table or flood criteria and the slope of the sides of the excavation, is controlled to protect sightlines, hazardous, or wasteful condition of the Property.

Application of David A. Bramble, Inc.

May 10, 2021

Page 8

The Applicant respectfully requests approval of the instant application for a special exception, subject to the conditions established in the most recent prior approval (Case No. 11-16).

Respectfully Submitted,
DAVID A. BRAMBLE, INC.



Megan B. Owings

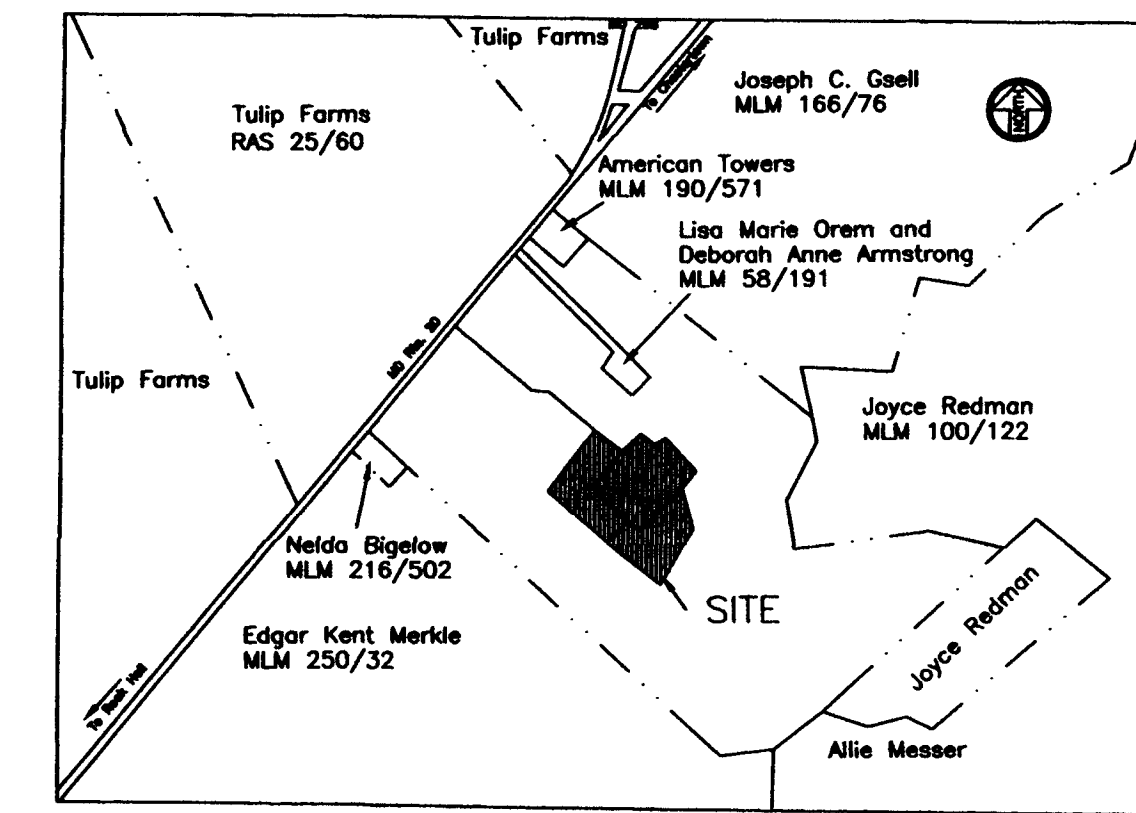

Trap No.	1	2	3	4
Trap Type	ST-III, Rip Rap Outlet	ST-III, Rip Rap Outlet	ST-III, Rip Rap Outlet	ST-II, Stone Outlet
D. A. To Trap (Acres)	7.5	2.5	6.4	1.9
Req'd Storage (CF)	40,500	13,500	34,560	6,840
Provided Storage (CF)	43,156	13,950	35,072	7,560
Bottom Dimensions	67X135	50X96	60X120	35X70
Bottom Elevation	31	41.5	26	39.5
Wier Crest Elevation	35	44	30	42
Top of Embankment Elevation	38	46.5	32.5	43
Wier Length (Feet)	10	5.5	15	8
Clean Out Elevation	32	42.75	27	40.75

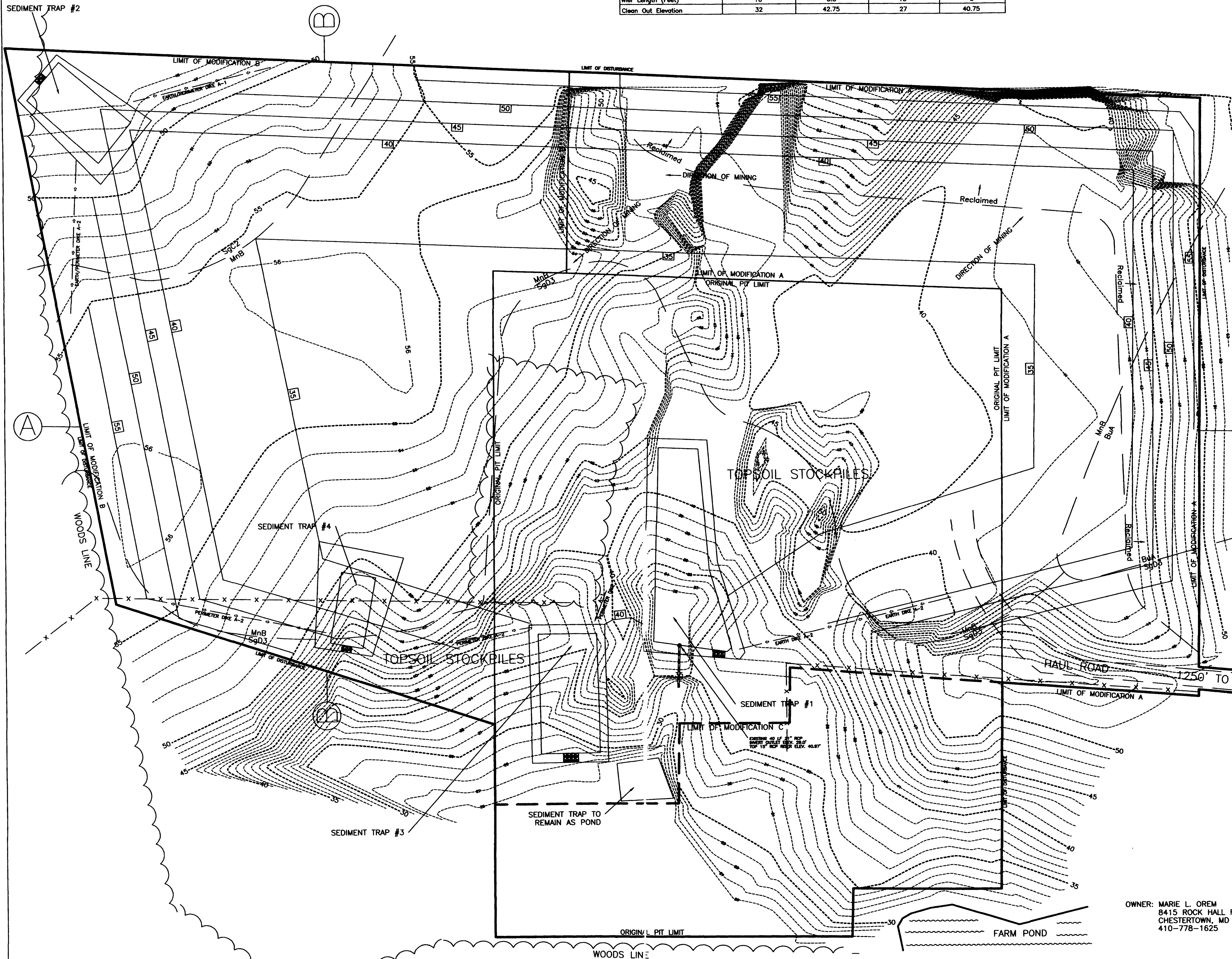

VICINITY MAP
SCALE = 1"=1400'



DEVELOPER'S CERTIFICATE

I (WE) CERTIFY THAT:

A. All development and construction will be done in accordance with this Sediment and Erosion Control Plan and/or Stormwater Management Plan, and further, authorize the right of entry for periodic on-site evaluation by the Kent County Sediment Control Inspector.

B. Any responsible personnel involved in the construction project will have a Certificate of Attendance at a Department of the Environment Approved Training Program for the Control of Sediment and Erosion before beginning the project.

C. It will be the responsibility of the contractor or the subcontractor to notify the engineer of any deviation from this Plan. Any change made in this plan without written authorization from the engineer will place responsibility for said change on the contractor or subcontractor.

Signature: *[Signature]* Date: 04/11/16
 Address: 705 MORGNEC RD, CHESTERTOWN, MD 21620
 Card No. 26325, Phone No. 410-778-3023

Legend

- Pit Limit/Limit of Disturbance
- Earth/Perimeter Dike
- Fence Line
- Existing Contours
- Proposed Contours
- Tree Line

OWNER: MARIE L. OREM
8415 ROCK HALL RD.
CHESTERTOWN, MD 21620
410-778-1625

Kent County Department of Health
 Signature _____ Date _____
 Kent County Department of Planning and Zoning
 Signature _____ Date _____

REVIEWED FOR KENT SOIL AND WATER CONSERVATION DISTRICT AND MEETS TECHNICAL REQUIREMENTS
 KENT SOIL AND WATER CONSERVATION DISTRICT DATE

DAVID A. BRAMBLE INC.
GENERAL CONTRACTORS
705 MORGNEC RD. PO BOX 419
CHESTERTOWN MD, 21620
410-778-3427
410-778-3023

DATE	BY
06/10/2004	SEWDAC
04/08/2016	

MINING PLAN MODIFICATION C
DUDLEY OREM BORROW PIT
 Kent County, Maryland
 Tax Map 42, Parcel 8, Lot 1

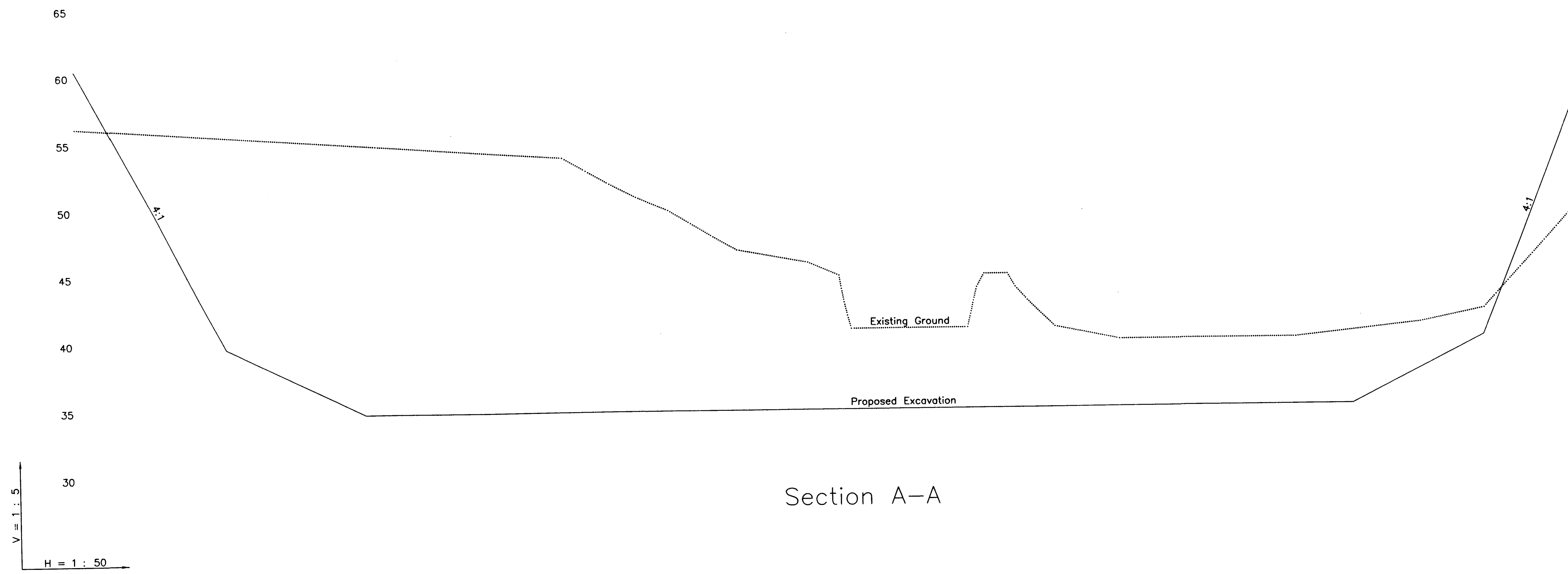

Section A-A

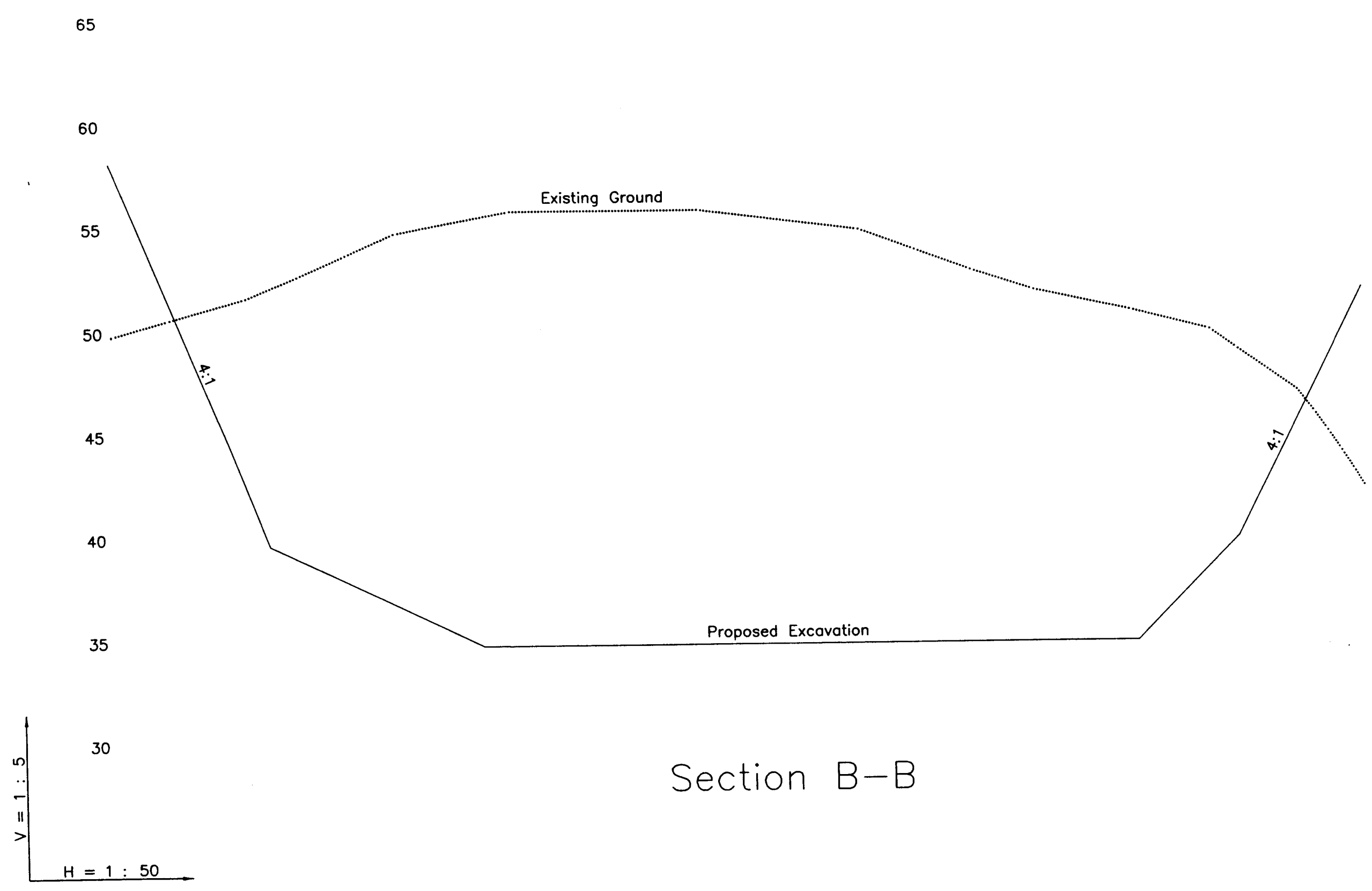

Section B-B

Kent County Department of Health	
Signature _____	Date _____
Kent County Department of Planning and Zoning	
Signature _____	Date _____

<p>CROSS SECTIONS</p> <p>DUDLEY OREM BORROW PIT Kent County, Maryland Tax Map 42, Parcel 8, Lot 1</p>	<p>DATE: 08/10/2004</p> <p>04/08/2016</p>	<p>REVIEWED FOR KENT SOIL AND WATER CONSERVATION DISTRICT AND MEETS TECHNICAL REQUIREMENTS</p> <p>KENT SOIL AND WATER CONSERVATION DISTRICT _____ DATE _____</p> <p>KENT SOIL & WATER CONSERVATION DISTRICT RESERVES THE RIGHT TO ADD, DELETE, MODIFY OR OTHERWISE ALTER THE SEDIMENT CONTROL PROVISIONS OF THIS PLAN IN THE EVENT ADDITIONAL PROTECTION BECOMES NECESSARY.</p>
	<p>DRAWN BY: SEW/DAC</p>	<p>DAVID A. BRAMBLE INC. GENERAL CONTRACTORS</p> <p>705 MORGNEC RD. PO BOX 419 CHESTERTOWN, MD. 21620</p> <p>FAX 410-778-3427 410-778-3023</p>

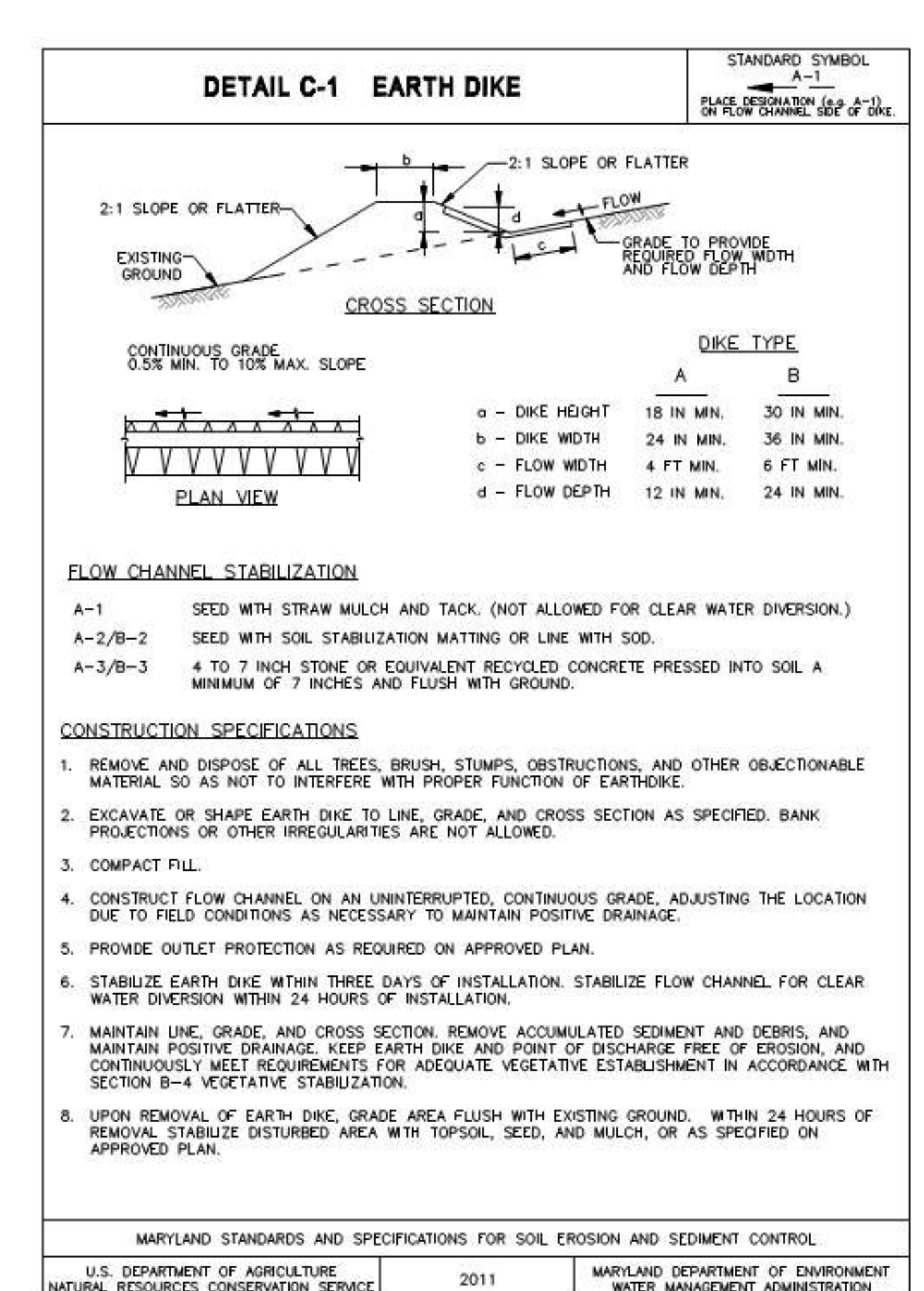
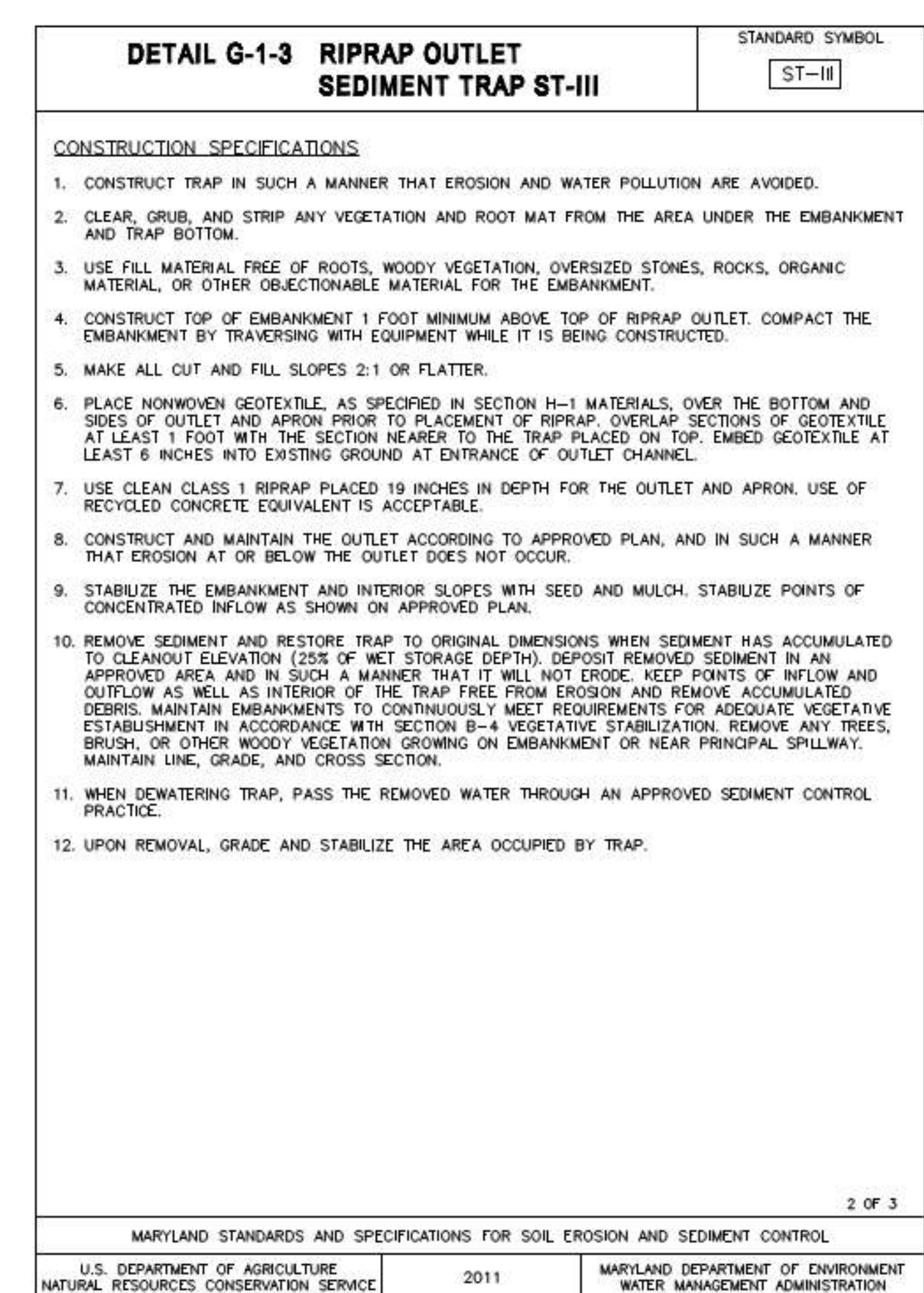
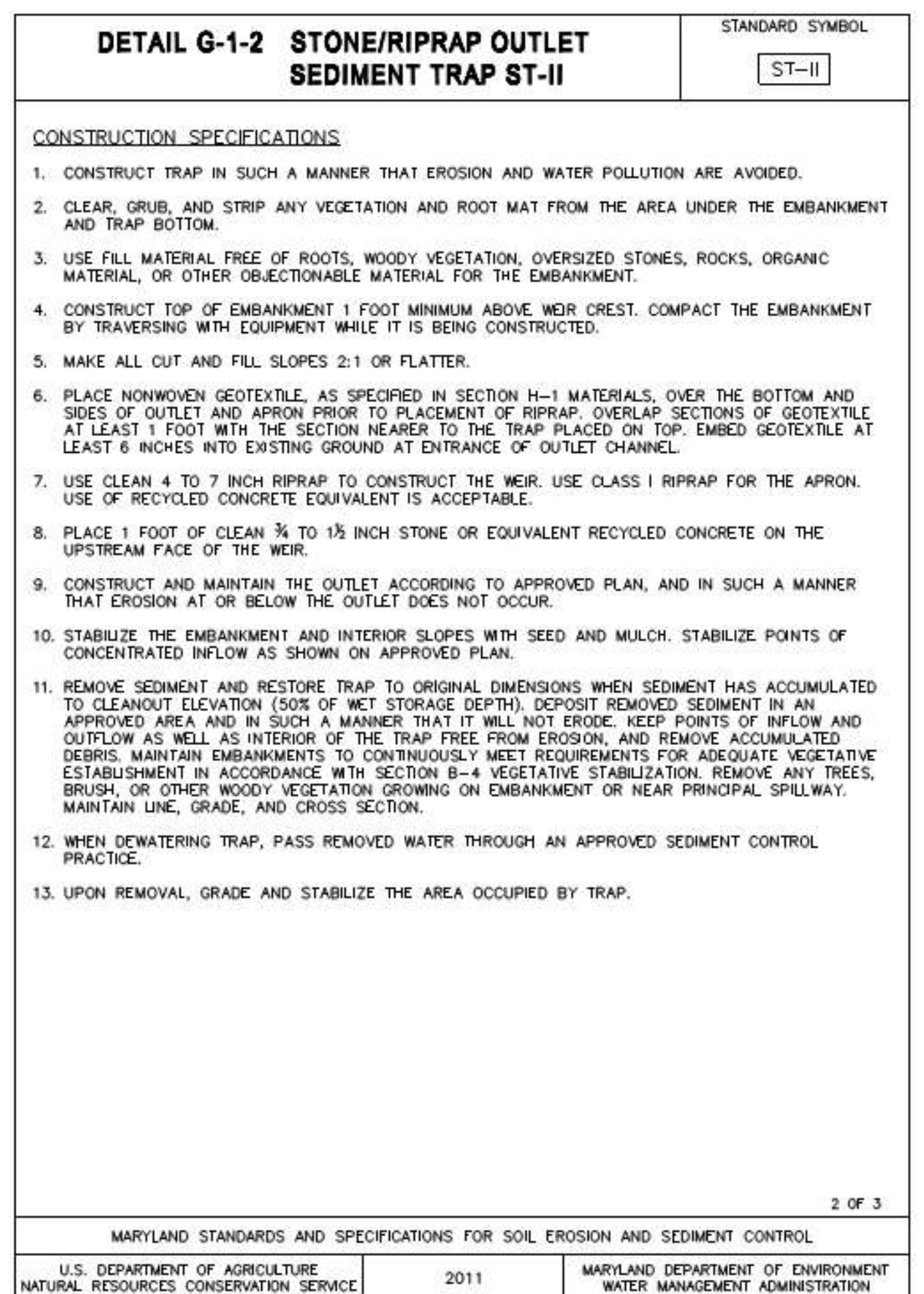
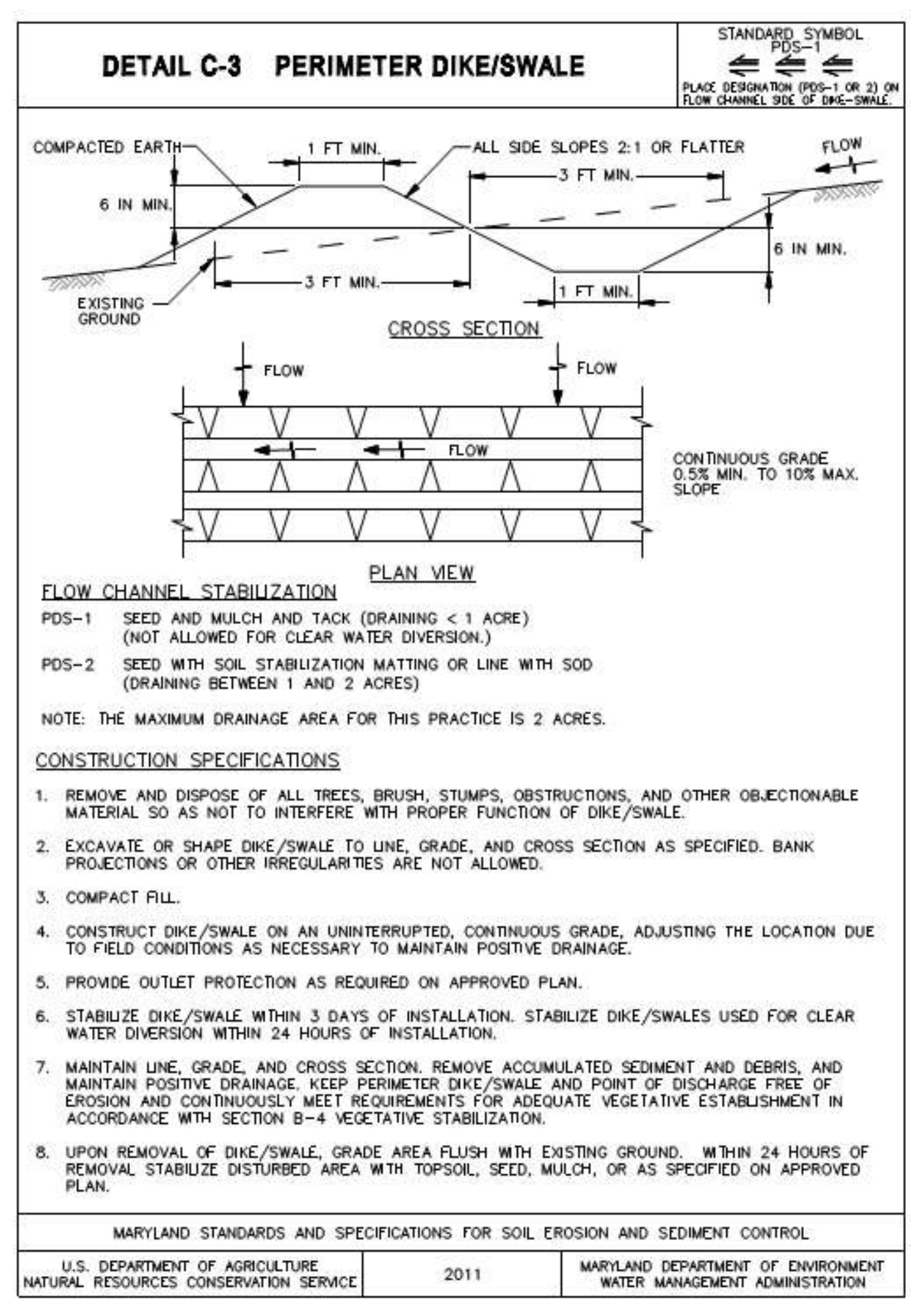
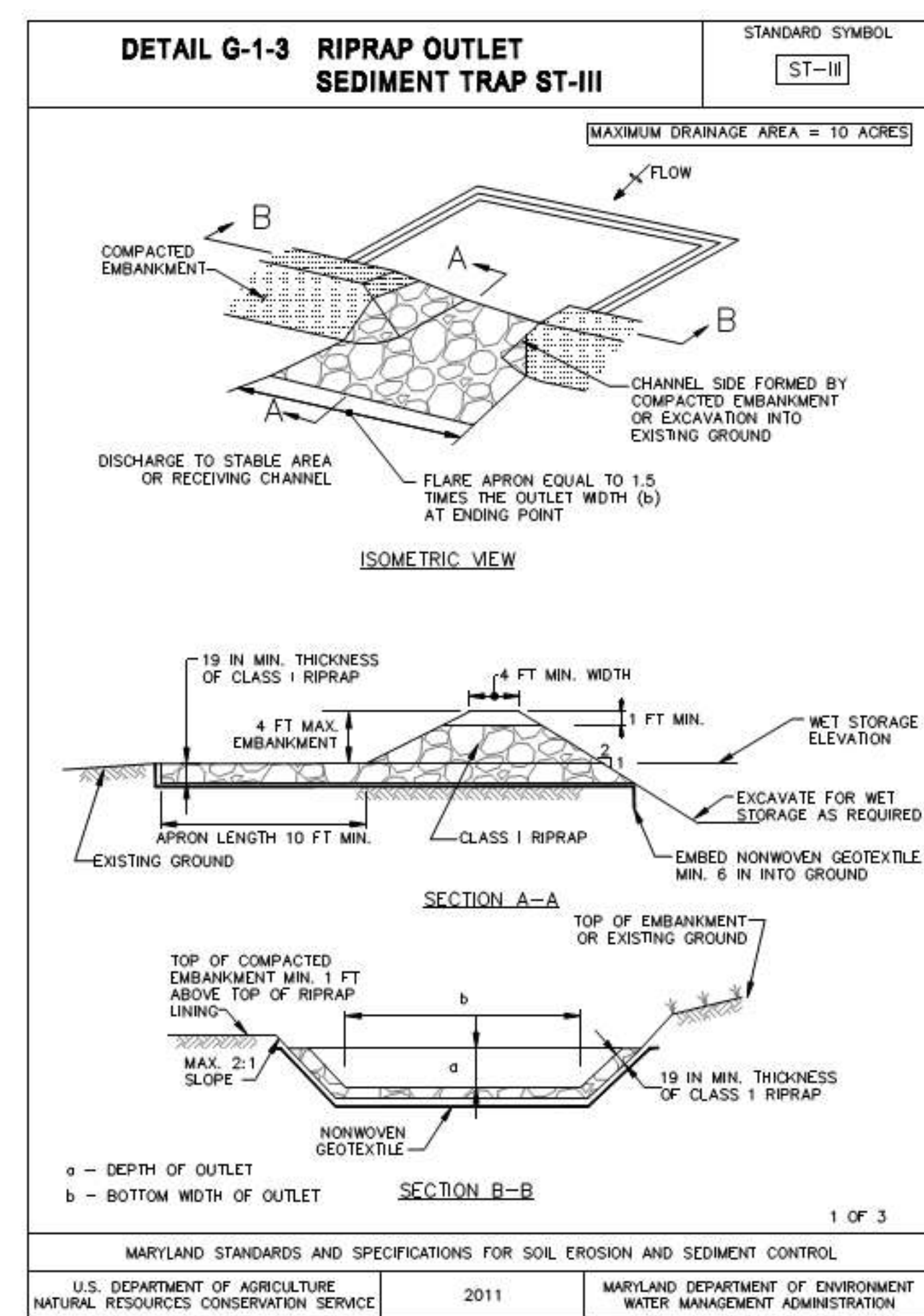
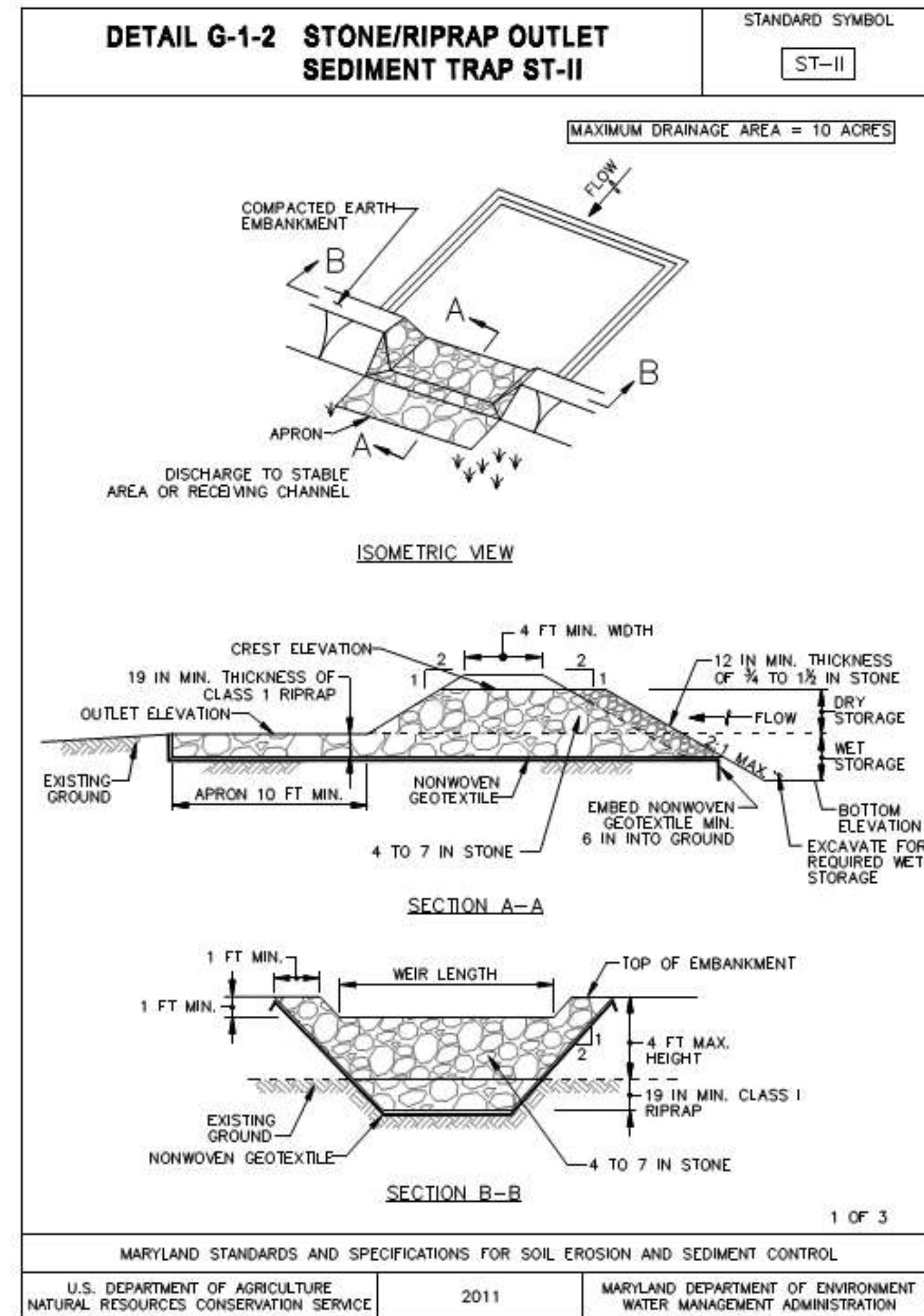

Kent County Department of Health

Signature _____ Date _____

Kent County Department of Planning and Zoning

Signature _____ Date _____

REVIEWED FOR KENT SOIL AND WATER CONSERVATION DISTRICT AND MEETS TECHNICAL REQUIREMENTS

KENT SOIL AND WATER CONSERVATION DISTRICT

DATE

DAVID A. BRAMBLE INC. GENERAL CONTRACTORS

705 MORGNEC RD., PO BOX 419 CHESTERTOWN, MD, 21620

DATE: 08/10/2004

DRAWN BY: SEWAC

04/08/2016

CROSS SECTIONS

DUDLEY OREM BORROW PIT

Kent County, Maryland

Tax Map 42, Parcel 8, Lot 1

SHEET 3 OF 4

EROSION AND SEDIMENT CONTROL NOTES, DETAILS AND SPECIFICATIONS

1. SEEDING (PERMANENT)

- (a) Shall be conducted between Feb. 1st to April 30th, August 15th to October 31st.
- (b) Seed bed preparation: apply 25 lbs. of 10-10-10 fertilizer per 1,000 sq. ft., harrow or disk into soil to a depth of 3 to 4 inches. Apply pulverized ground limestone at a rate of 50 lbs. per 1,000 sq. ft.
- (c) Seed application: Apply 2.3 lbs per 1,000 square ft or 100 lbs per acre of Kentucky 31 Tall Fescue on a moist seed bed with suitable equipment; minimum cover ¼ inch. Apply one bushel small grain seed (wheat, barley, rye, etc.) per acre.
- (d) Mulch: immediately after seeding, uniformly mulch entire area with unweathered small grain straw at a rate of 1 ½ to 2 tons per acre. Mulch to be anchored with mulch anchoring tool on the center or asphalt tie down method (on ditches only).

2. TEMPORARY STABILIZATION

- (a) Provide seed bed same as 1-b above.
- (b) Provide temporary seeding at a rate of 150 lbs./ac. (3.44 lbs./1000 sq. ft.) annual rye seed.
- (c) Mulch same as 1-d above.

3. If temporary stabilization is required, permanent seeding shall be performed during the next applicable period (see statement 1-a above).

4. All fill slope areas shown on the plans are to be stabilized as per statement 1 or 2 above immediately after completion of grading operations for these slopes.

5. Clear and grub all fill areas shown on plan.

6. Roadside ditches shall be constructed with 4:1 side slopes. All ditches shall be seeded with 4:1 side slopes. All ditches shall be seeded in accordance with 1-b above.

7. Ditches shall be stabilized after placement of seed and mulch with Excelsior Matting. The centerline of all ditches shall have a minimum of one (1) standard width of matting except where grades are in excess of 3%. Then the double width of matting shall be provided.

8. Riprap and approved filter cloth shall be placed at all culverts as shown on the plans.

9. All Erosion and Sediment Control devices and stabilization shall conform to Kent Soil and Water Conservation District standards and specifications.

Table B.3: Selected List of Permanent Herbaceous Seeding Mixtures (Continued)

Mix	Recommended Cultivar	Seeding Rate ^{1/}		Soil Drainage Class ^{2/}	Max. Height (inch)	Maint. Level ^{3/}	Remarks
		lb/ac	lb/1000 ft ²				
11. Creeping Red Fescue (<i>Festuca rubra</i> var. <i>rubra</i>)	Dawson, Pennlawn, Flyer, Fortless, Ruby, or Salem	30	0.69				
Chewings Fescue (<i>Festuca rubra</i> ssp. <i>commutata</i>)	Common	30	0.69				
Kentucky Bluegrass (<i>Poa pratensis</i>)	Recommended MD turf-types ^{2/}	20	0.46	E - MW	2 - 3	B - D	
OPTIONAL ADDITION							
Rough Bluegrass (<i>Poa trivialis</i>)	Common	15	0.34				Add rough bluegrass in moist, shady conditions.
→ 12. Creeping Red Fescue (<i>Festuca rubra</i> var. <i>rubra</i>)	Dawson, Pennlawn, Flyer, Fortless, Ruby, or Salem	25	0.57				Attractive mix of fine fescues and wildflowers for low maintenance conditions. Once well-established, the grasses may tend to outcompete the wildflowers.
Hard Fescue (<i>Festuca trachyphylla</i>)	Atila or Aurora	25	0.57				
Sheep Fescue (<i>Festuca ovina</i>)	Common or Bighorn	25	0.57				Wildflowers are best established by broadcasting and cultipacking on a prepared seedbed. Drilling can be also used, but care must be taken so that seeds are not drilled too deep.
PLUS WILDFLOWER MIX:							
Black-eyed Susan (<i>Rudbeckia hirta</i>)	Common	2	0.05	E - MW	2 - 3	C - D	Hydroseeding is not recommended for this mix if wildflowers are used. (They have very small seeds.)
Lance-leaved Coreopsis (<i>Coreopsis lanceolata</i>)	Common	2	0.05				
Purple Coneflower (<i>Echinacea purpurea</i>)	Common	2	0.05				
Partridge Pea (<i>Chamaecrista fasciculata</i>)	Common	5	0.11				
OR ADD CLOVER MIX:							
White Clover (<i>Trifolium repens</i>)	Common	3	0.07				
Red Clover (<i>Trifolium pretense</i>)	Any	3	0.07				

GENERAL NOTES

1. Notification of Kent County sediment and erosion control inspector at 410-778-7437 at least five (5) days prior to the start of work.
2. Prior to the start of work, the Contractor is to obtain County approval of any proposed changes and sequence of construction, specifically relating to installation, inspection, maintenance and removal of erosion and sediment control measures.
3. Sediment control measures are not to be removed until the areas served have established vegetative cover, or with the permission of the County Sediment Control Inspector.
4. When pumping sediment-laden water, the discharge must be directed to approved sediment trapping measure prior to release from the site.
5. All temporary stockpiles are to be located within areas protected by sediment control measures, and are to be temporarily stabilized.
6. All sediment control dikes, swales, basins and flow lines to basins will be temporarily seeded immediately upon installation to reduce the contribution to sediment loading.
7. Disposal of excess earth materials on State or Federal property requires MDE approval, otherwise materials are to be disposed of at a location approved by the local authority.
8. Temporary soil erosion control and sediment control measures are to be provided as per the approved plan prior to grading operation. Location adjustments are to be made in the field as necessary. The minimum area practical shall be disturbed for the minimum possible time.
9. If grading is completed out of seeding season, graded areas are to be temporarily stabilized by mulch and mulch anchoring. Mulch material shall be un-weathered, un-chopped small grain straw spread at the rate of 1 ½ to 2 tons per acre. Mulch anchoring to be accomplished by an approved method, use of a mulch anchoring tool is recommended where possible.
10. Implementation of the sediment control plan shall be in accordance with the "2011 Maryland Standards and Specifications for Soil Erosion and Sediment Control", of the Department of the Environment.
11. The Contractor is responsible for implementation and maintenance of the approved plan, and all other measures necessary to control, filter, or prevent sediment from leaving the site.
12. In cases where storm water management structures are a part of site development, removal of sediment control may not be accomplished before the contributing area to the storm water management structure is stabilized.
13. On sites where infiltration techniques are utilized for the control of storm water, extreme care must be taken to prevent all runoff from entering the structure during construction.
14. Sediment control for utility construction in areas outside of designed controls:
 - a. Excavated trench material shall be placed on the high side of the trench.
 - b. Immediately following pipe installation the trench shall be backfilled, compacted and stabilized at the end of each working day.
 - c. Temporary silt fence or straw bale dikes shall be placed immediately downstream of any disturbed area intended to remain disturbed longer than one working day.
15. All points of construction ingress and egress shall be protected to prevent tracking of mud onto public ways.

16. Site Information:
Total Area of Site 153 Acres

Area Disturbed 15.0 Acres

Total Cut 90,000 Cu. Yds.

Total Fill None Cu. Yds.

Offsite Waste/Borrow None
Area Location

Table B.5: Recommended Planting Dates for Permanent Cover in Maryland ^{1/}

Type of Plant Material	Plant Hardiness Zones		
	5b and 6a	6b	7a and 7b
Seeds - Cool-Season Grasses (includes mixes with forbs and/or legumes)	Mar 15 to May 31 Aug 1 to Sep 30	Mar 1 to May 15 Aug 1 to Oct 15	Feb 15 to Apr 30 Aug 15 to Oct 31 Nov 1 to Nov 30
Seeds - Warm-Season/Cool-Season Grass Mixes (includes mixes with forbs and/or legumes)	Mar 15 to May 31 ♦♦ Jun 1 to Jun 15*	Mar 1 to May 15 ♦♦ May 16 to Jun 15*	Feb 15 to Apr 30 ♦♦ May 1 to May 31*
Sod - Cool-Season	Mar 15 to May 31 Jun 1 to Aug 31* Sep 1 to Nov 1*+	Mar 1 to May 15 May 16 to Sep 14* Sep 15 to Nov 15*+	Feb 15 to Apr 30 May 1 to Sep 30* Oct 1 to Dec 1*+
Unrooted Woody Materials; Bare-Root Plants; Bulbs, Rhizomes, Corms, and Tubers	Mar 15 to May 31 Jun 1 to Jun 30*	Mar 1 to May 15 May 16 to Jun 30*	Feb 15 to Apr 30 May 1 to Jun 30*
Containerized Stock; Balled-and-Burlapped Stock	Mar 15 to May 31 Jun 1 to Jun 30* Sep 1 to Nov 15*+	Mar 1 to May 15 May 16 to Jun 30* Sep 15 to Nov 30*+	Feb 15 to Apr 30 May 1 to Jun 30* Oct 1 to Dec 15*+

- Notes:**
1. The planting dates listed are averages for each zone. These dates may require adjustment to reflect local conditions, especially near the boundaries of the zones. When seeding toward the end of the listed planting dates, or when conditions are expected to be less than optimal, select an appropriate nurse crop from Table B.1 Temporary Seeding for Site Stabilization and plant together with the permanent seeding mix.
 2. When planted during the growing season, most of these materials must be purchased and kept in a dormant condition until planting. Bare-root grasses are the exception—they may be supplied as growing (non-dormant) plants.
 - ♦ Additional planting dates for the lower Coastal Plain, dependent on annual rainfall and temperature trends. Recommend adding a nurse crop, as noted above, if planting during this period.
 - ♦♦ Warm-season grasses need a soil temperature of at least 50 degrees F in order to germinate. If soil temperatures are colder than 50 degrees, or moisture is not adequate, the seeds will remain dormant until conditions are favorable. In general, planting during the latter portion of this period allows more time for weed emergence and weed control prior to planting. When selecting a planting date, consider the need for weed control vs. the likelihood of having sufficient moisture for later plantings, especially on droughty sites.
 - * Additional planting dates during which supplemental watering may be needed to ensure plant establishment.
 - + Frequent freezing and thawing of wet soils may result in frost-heaving of materials planted in late fall, if plants have not sufficiently rooted in place. Soil usually needs 4 to 6 weeks to become sufficiently rooted. Large containerized and balled-and-burlapped stock may be planted into the winter months as long as the ground is not frozen and soil moisture is adequate.

INSPECTION CHECKLIST

The contractor shall notify the Kent County Sediment Control Inspector (410-778-7437) at the following points:

1. The required pre-construction meeting.
2. Following installation of sediment control measures.
3. During the installation of the sediment basins.
 - Notification shall be for each step.
 - a. clearing and grubbing
 - b. core trench installation
 - c. pipe and anti-seep collar installation
 - d. during dam fill
 - e. emergency spillway installation
 - f. completion of structure
4. Prior to removal or modification of any sediment control structure.
5. Prior to removal of all sediment control measures.
6. Prior to final acceptance.

NOTE TO CONTRACTOR

EROSION AND SEDIMENT CONTROL WILL BE STRICTLY ENFORCED

STANDARD STABILIZATION NOTE

Following initial soil disturbance or re-disturbance, permanent or temporary stabilization must be completed within:

- a.) Three (3) calendar days as to the surface of all perimeter dikes, swales, ditches, perimeter slopes, and all slopes steeper than 3 horizontal to 1 vertical (3:1); and
- b.) Seven (7) calendar days as to all other disturbed or graded areas on the project site not under active grading.

CONSTRUCTION SEQUENCE

1. Prior to any construction, notify the Maryland Department of Environment inspector at 410-631-8055, Minerals, Oil, and Gas Division and Kent Soil and Water Conservation District at 410-778-5150 to arrange a pre-construction meeting.
2. Construct the new Sediment Trap 1 in accordance with the 2011 Maryland standards and fill/remove the existing sediment trap.
3. Upon approval, place the initial perimeter sediment control features indicated on the plans.
4. Clear and strip topsoil, placing it in the area shown on the pit floor.
5. Excavate pit, mining to the limits indicated.
6. Sediment traps must be in place prior to mining the area that they protect.
7. As mining progresses, Sediment Traps 2 and 4 will cease to function. Sediment Trap 3 must be complete prior to the abandoning of Sediment Trap 4.
8. At the completion of mining, all slopes and the floor of the pit are to be topsoiled, seeded, and mulched in accordance with the approved mining plan.
9. Prior to the removal of the remaining sediment traps and other sediment control features, approval must be obtained from the appropriate authorities indicated in step 1 of this sequence.

Kent County Department of Health	
Signature _____	Date _____
Kent County Department of Planning and Zoning	
Signature _____	Date _____

REVIEWED FOR KENT SOIL AND WATER CONSERVATION DISTRICT AND MEETS TECHNICAL REQUIREMENTS

KENT SOIL AND WATER CONSERVATION DISTRICT

DATE

KENT SOIL & WATER CONSERVATION DISTRICT RESERVES THE RIGHT TO ADD, DELETE, MODIFY OR OTHERWISE ALTER THE SEDIMENT CONTROL PROVISIONS OF THIS PLAN IN THE EVENT ADDITIONAL PROTECTION BECOMES NECESSARY.

DAVID A. BRAMBLE, INC. GENERAL CONTRACTORS

FAX 410-778-3427 410-778-3023

705 MORGNEC RD., PO BOX 419 CHESTERTOWN, MD, 21620

CROSS SECTIONS

DUDLEY OREM BORROW PIT
Kent County, Maryland
Tax Map 42, Parcel 8, Lot 1

DRAWN BY: SEM/DAC

DATE: 08/10/2004

04/08/2016

SHEET 4 OF 4

RECEIVED
CLERK OF CIRCUIT COURT
2018 JUN 21 10 28 AM
KENT COUNTY

LR - Plat Fee - 12.00
General Survey/Book - 197A
Dismemberment - 197A
Ref. Plat. Book 5, 197A
Taxes: 12.00
06/21/2018 02:11:11
#18586278 CC0264
Kent County/CORR: 03.01
- Resurveyed

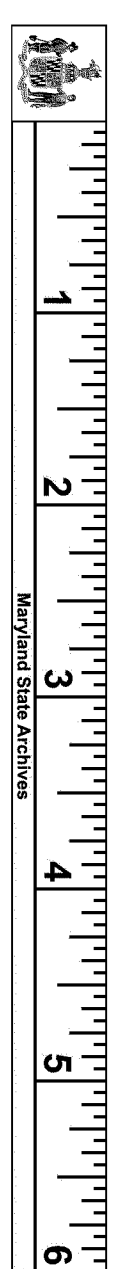
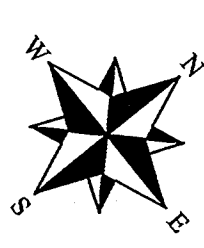
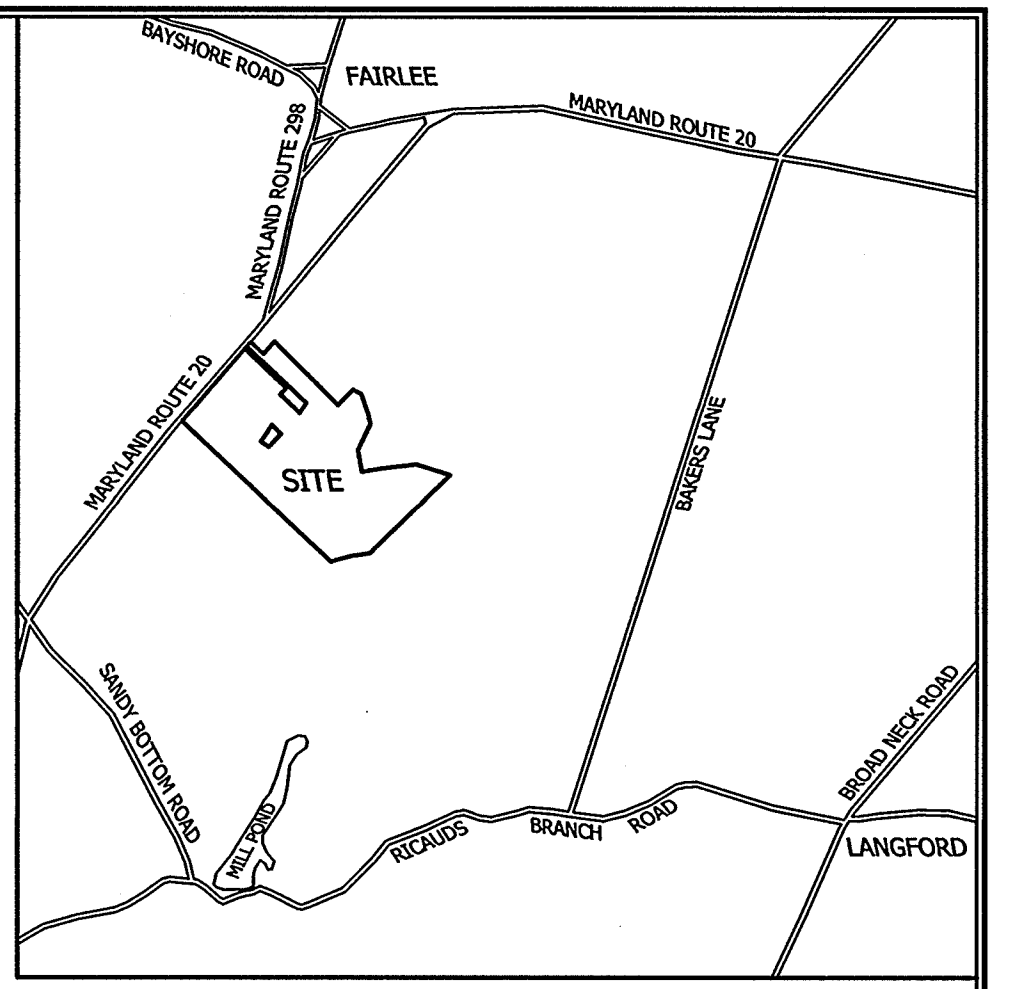

PARCEL 126
LANDS OF
MICHAEL D. HILDEBRAND et ux.
M.L.M. 546/85

PARCEL 8A
LANDS OF
AMERICAN TOWERS INC.
M.L.M. 150/571

SUBDIVISIONS SINCE DECEMBER 1969 -
3.129 ACRES TO LISA M. OREM - 4-29-94 PER M.L.M. 58/191
1.350 ACRES TO LEE ANN OREM MARVEL et al. - 10-10-07 PER M.L.M. 540/585
AREA OF FARM AS OF DECEMBER 1969 - 182.994AC±
10% OF WHICH = 18.299AC±
TOTAL AREA OF OUTCONVEYANCES = 16.323AC±

LINE	BEARING	DISTANCE
1	S 38°01'26" E	7.38
2	S 44°04'59" E	89.27
3	S 49°00'17" E	95.27
4	S 40°45'04" E	20.52
5	S 39°22'25" W	296.81
6	N 59°15'40" W	161.68
7	N 30°44'21" E	342.97
8	N 30°44'20" E	242.97
9	N 59°15'40" W	406.01
10	N 01°37'55" W	218.72
11	N 38°08'19" W	711.69
12	N 39°15'55" E	51.23
13	S 38°08'19" E	739.33
14	S 01°37'55" E	207.71
15	S 59°15'40" E	378.51
16	S 30°44'22" W	50.00

PARCEL 25
LANDS OF
EDGAR KENT MERKLE, Trustee
M.L.M. 814/467

PARCEL 36
LANDS OF
JOSEPH C. GSELL et ux.
M.L.M. 166/76

PARCEL 8, LOT 1
LANDS OF
MARIE L. OREM et al.
M.L.M. 910/94
EXISTING AREA
178.766AC±
RESULTING AREA
166.651AC±

PARCEL 6
LANDS OF
JOYCE D. REDMAN
E.H.P. 230/313

PARCEL 11
LANDS OF
LANGFORD WEST LLC
M.L.M. 933/124

PARCEL 40
LANDS OF
JOYCE D. REDMAN
M.L.M. 100/122

SITE CURRENTLY ZONED - AZD - AGRICULTURAL
--- DENOTES EXISTING PROPERTY LINE
- - - DENOTES PROPOSED PROPERTY LINE
- - - DENOTES PROPERTY LINE TO BE REMOVED
ALL MEASUREMENTS SHOWN HEREON ARE THE
RESULT OF A FIELD RUN SURVEY

APPROVED:
[Signature]
DATE: 6/20/18
KENT COUNTY DIRECTOR OF PLANNING

APPROVED:
[Signature]
DATE: 6/20/18
KENT COUNTY HEALTH DEPT. APPROVING AUTHORITY

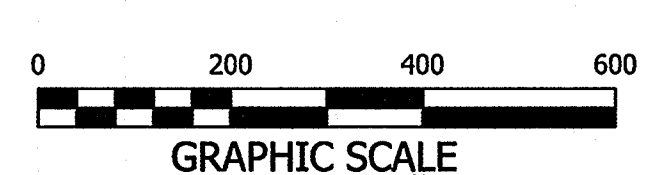

KENT COUNTY HAS ADOPTED A RIGHT TO FARM LAW THAT PROTECTS AGRICULTURAL OPERATIONS IF SUCH OPERATIONS ARE CONDUCTED IN ACCORDANCE WITH GENERAL ACCEPTED AGRICULTURAL PRACTICES. THIS SUBDIVISION IS LOCATED ADJACENT TO OR NEAR AGRICULTURAL OPERATIONS AND THE OWNERS OF THESE LOTS MAY BE SUBJECT TO INCONVENIENCES ARISING FROM SUCH OPERATIONS.

LOT LINE ADJUSTMENT
OF THE LANDS OF,
MARIE L. OREM et al.
SIXTH ELECTION DISTRICT, KENT COUNTY, MARYLAND
TAX MAP 42, PARCEL 8

SCALE
1"=200'
DRAWN BY
RAM
DATE
6-20-18
JOB NO.
926
REVISIONS

EXTREME MEASURES
LAND SURVEYORS
Chestertown, MD 21620 PHONE 410-778-0147
www.extrememeasuresllc.com

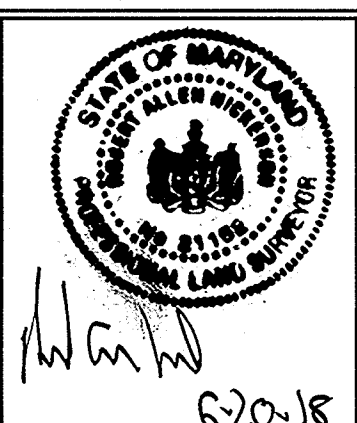

RECEIVED
CLERK OF COURT
2018 JUN 21 P 2:40
KENT COUNTY

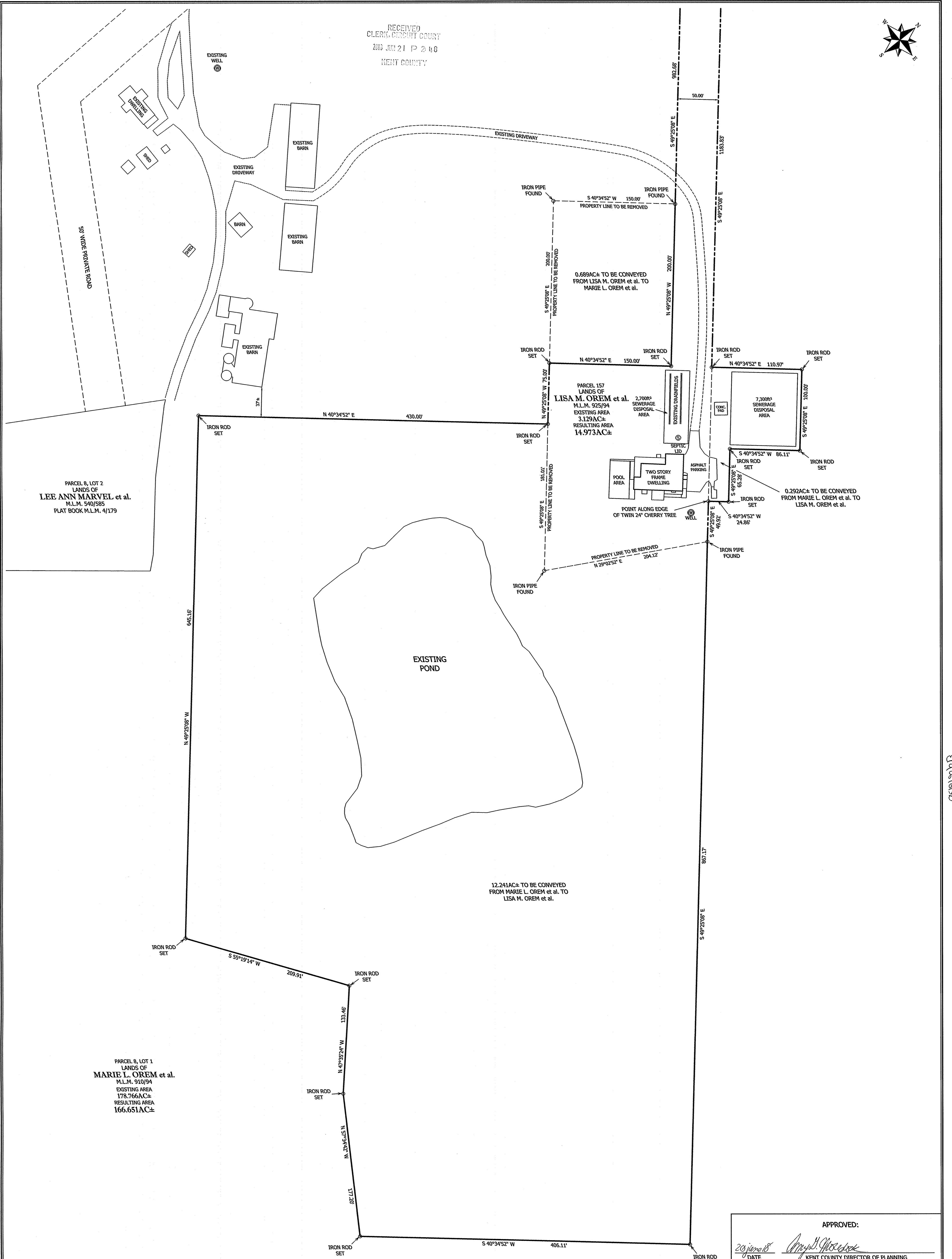
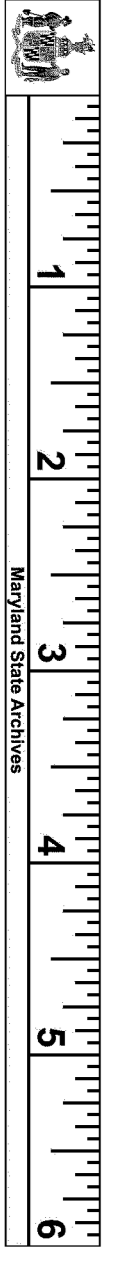
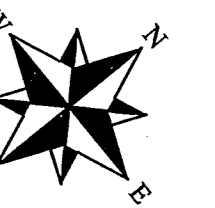

SITE CURRENTLY ZONED - AZD - AGRICULTURAL

--- DENOTES EXISTING PROPERTY LINE
- - - DENOTES PROPOSED PROPERTY LINE
- - - DENOTES PROPOSED PROPERTY LINE
ALL MEASUREMENTS SHOWN HEREON ARE THE RESULT OF A FIELD RUN SURVEY



KENT COUNTY HAS ADOPTED A RIGHT TO FARM LAW THAT PROTECTS AGRICULTURAL OPERATIONS IF SUCH OPERATIONS ARE CONDUCTED IN ACCORDANCE WITH GENERAL ACCEPTED AGRICULTURAL PRACTICES. THIS SUBDIVISION IS LOCATED ADJACENT TO OR NEAR AGRICULTURAL OPERATIONS AND THE OWNERS OF THESE LOTS MAY BE SUBJECT TO INCONVENIENCES ARISING FROM SUCH OPERATIONS.

APPROVED:
20 June 18 *Amel G...*
DATE KENT COUNTY DIRECTOR OF PLANNING

APPROVED:
6/20/18 *John C...*
DATE KENT COUNTY HEALTH DEPT. APPROVING AUTHORITY

LOT LINE ADJUSTMENT
OF THE LANDS OF,
MARIE L. OREM et al.
SIXTH ELECTION DISTRICT, KENT COUNTY, MARYLAND
TAX MAP 42, PARCEL 8

SCALE 1"=50'
DRAWN BY RAN
DATE 6-20-18
JOB NO. 926
REVISIONS

EXTREME MEASURES
LAND SURVEYORS
Chestertown, MD 21620 PHONE 410-778-0147
www.extrememeasuresllc.com

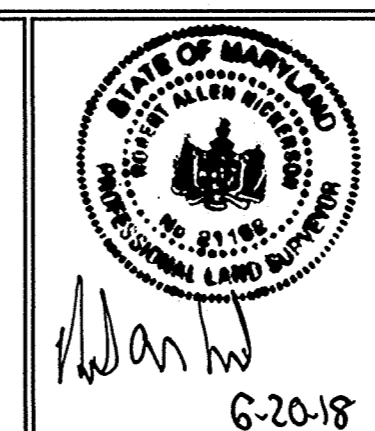

6-20-18



Kent County Department of Planning, Housing, and Zoning

To: Kent County Planning Commission
From: Carla Gerber, Deputy Director
Meeting: June 3, 2021
Subject: 2020 Annual Report

EXECUTIVE SUMMARY

Attached is the 2020 MDP Short Form Annual Report letter. As required by the General Assembly under Land Use Article §1-207 (basic requirements), §7-104 (adequate facilities reporting requirements), and §1-208 (measures and indicators), all planning commissions and planning boards with planning and zoning authority are required to prepare and submit an annual report by July 1. The report must be adopted by the Planning Commission and filed with the County Commissioners.

At this time, we are presenting the minimum report required to comply with State law. We anticipate sharing our traditional annual report with you in the near future.

Despite the Covid-19 pandemic, development activity did not fall off significantly. Only 45 fewer permits were processed in 2020 than in 2019, and the number of new house permits increased from 24 to 34. Six major site plans were submitted; two were for new businesses and the others were for the expansion and enhancement of existing businesses.

Accessory buildings and residential additions/alterations continue to account for the greatest number of permits, followed by demolition. Although it should be noted that many accessory buildings and residential additions/alterations also have an associated demolition permit.

All of the Boards and Commissions that are staffed by the Department continued to meet as needed throughout 2020, and we even started the Comprehensive Rezoning process. The shift to virtual meetings represents a new way for the Department to conduct business and moving forward will continue to provide opportunities for applicants and the public to easily participate in the process.



Department of Planning,
Housing, and Zoning
400 High Street, Suite 130
Chestertown, MD 21620
410-778-7423 (voice/relay)
planning@kentgov.org

June XX

Office of the Secretary
Maryland Department of Planning
Attn: David Dahlstrom, AICP
301 W. Preston St.
Baltimore, Maryland 21201-2305

Re: Annual Report Calendar Year 2020

Dear Mr. Dahlstrom:

The Kent County Planning and Zoning Commission approved the following Annual Report for the Reporting Year 2020 as required under [§1-207\(b\)](#) of the Land Use Article on June 3, 2020. In addition, this report has been filed with the local legislative body.

1. The County issued the following number of new Residential Permits inside and outside of the Priority Funding Area (PFA), [§1-208\(c\)\(1\)\(i\)](#) and [\(c\)\(3\)\(ii\)](#):

**Table 1: New Residential Permits Issued
Inside and Outside the Priority Funding Area (PFA)**

Residential – Calendar Year 2020	PFA	Non - PFA	Total
# New Residential Permits Issued	14	20*	34

* Only 5 new dwellings were located within the Priority Preservation Area, and 3 of those were replacement dwellings.

2. The County preserved the following number of acres using local agricultural land preservation funding, [§1-208\(c\)\(iv\)](#), (if applicable):

Kent County does not have a locally funded land preservation program.

3. The County is scheduled to complete and submit a 5-Year Mid-Cycle comprehensive plan implementation review report this year, as required under §1-207(c)(6) of the Land Use Article?

Y N

The most recent Comprehensive Plan was adopted in April 2018.

4. The County is scheduled to update its' Development Capacity Analysis this year, as required under [§1-208\(2\)\(c\)\(iii\)](#) of the Land Use Article? Y N

If no, please indicate when the next Development Capacity Analysis will be completed.

The next Development Capacity Analysis is due in 2021. Staff will be contacting our regional planner for assistance.

5. Were there any growth related changes, including Land Use Changes, Zoning Ordinance Changes, New Schools, Changes in Water or Sewer Service Area, etc., pursuant to [§1-207\(c\)\(1\)](#) of the Land Use Article? If yes, please list or provide maps. Y N

The only change to a service area was to include several existing lots that were inadvertently left out of the service area. No map amendments were processed. Five zoning text amendments were reviewed, but none were related to allowing or encouraging additional growth.

6. Did your jurisdiction identify any recommendations for improving the planning and development process within the jurisdiction? If yes, list. Y N

The County has begun a Comprehensive Rezoning Update. It is anticipated that changes will be made to the planning and development process to clarify procedures and timelines and alter the process by which some uses and site plans are reviewed.

7. Are there any issues that Planning can assist you with in 2021? If yes, please list. Y N

As the County undertakes comprehensive rezoning, we greatly appreciate the continued assistance of our MDP liaison, who is always helpful and ready to assist the County.

8. Have all members of the Planning Commission and Board of Appeals completed an educational training course as required under §1-206(a)(2) of the Land Use Article? Y N

Sincerely,

(Name Planning Director, Chair, Administrator, Project Manager or Clerk)